



Pierce Enforcer Pumper
Township of Pennsauken
Job #38420

FEATURES & SPECIFICATIONS

- Pierce Enforcer 70" Chassis with a Flat Roof
- Cummins L9 450hp 2021 EPA compliant Engine
- Allison EVS3000P Automatic Transmission
- TAK-4 Independent Front Suspension
- Waterous CSU 2000 GPM Single Stage Pump
- 500 Gallon Poly "New York Style" Water Tank
- Harrison MSV 6kW Hydraulic Generator
- Delivered in March 2024



**FIRE & SAFETY
SERVICES**

South Plainfield, NJ
www.f-ss.com · 800-400-8017



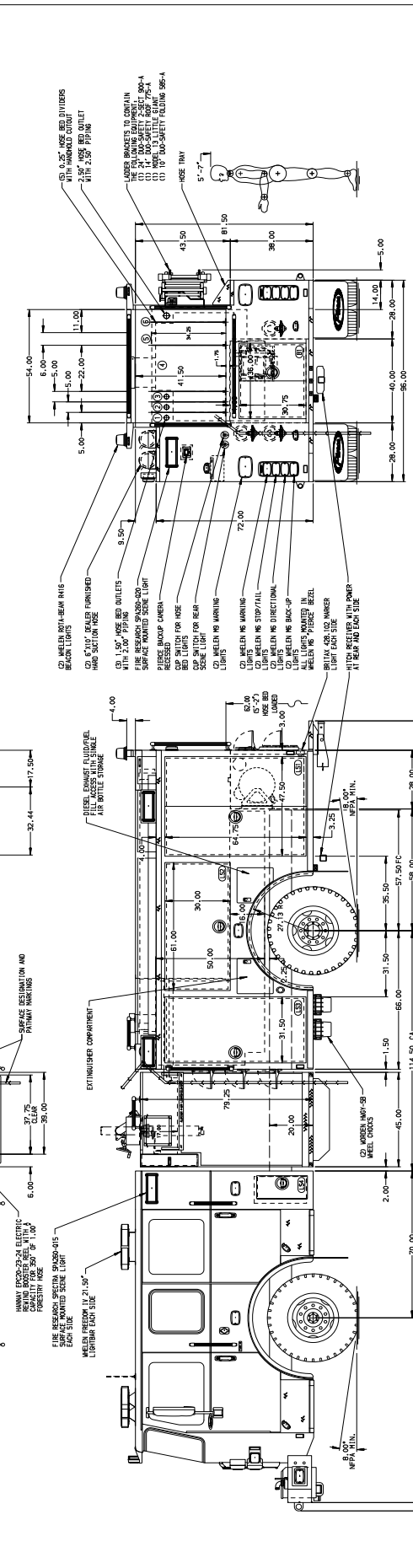
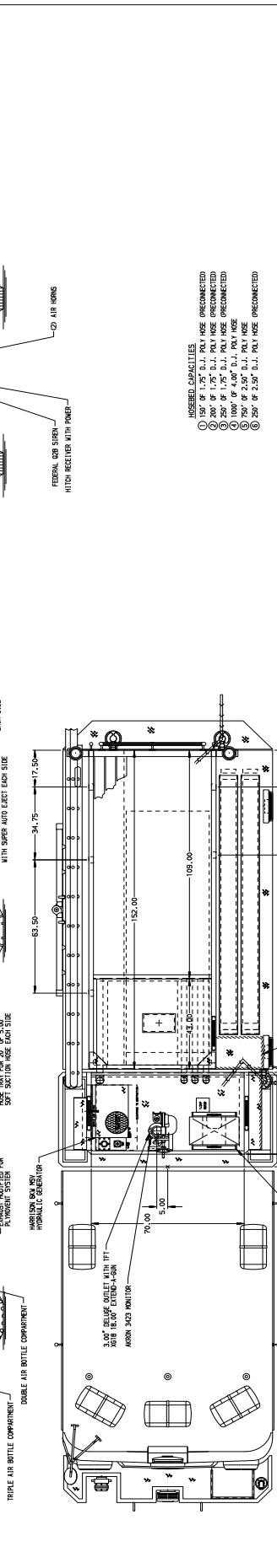
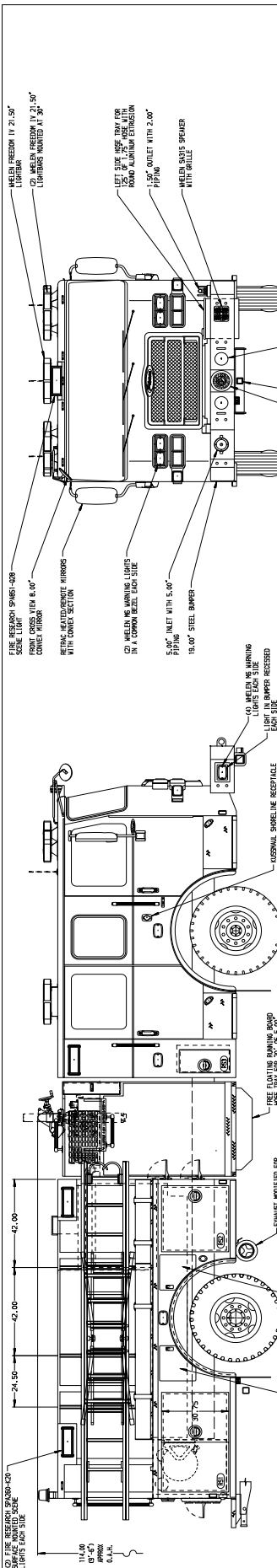

HOSED CAPACITIES
 ① 150' OF 1.75" D.I. POLY HOSE (PRECONNECTED)
 ② 200' OF 1.75" D.I. POLY HOSE (PRECONNECTED)
 ③ 1000' OF 1.75" D.I. POLY HOSE (PRECONNECTED)
 ④ 1000' OF 2.50" D.I. POLY HOSE (PRECONNECTED)
 ⑤ 750' OF 2.50" D.I. POLY HOSE (PRECONNECTED)
 ⑥ 250' OF 2.50" D.I. POLY HOSE (PRECONNECTED)

STAINLESS STEEL BODY (MAXIMUM O.A.H. 118.00") SIDE ROLL AND FRONTAL IMPACT PROTECTION
 1. NO. 6 USE LOCKS PER PANEL DIVISION LOOSE. USE PUMP PANEL PER ORDER.
 2. USE 1/2\"/>

JOB NO. 38420		SCALE 1:24	DATE 26 APR 23
DRAWN BY BST		CHECKED BY PHA	SHEET NO. 1 OF 1
ORDERED BY PHA		MANUFACTURING INC.	
TITLE 2000-D-500P-152' PUMPER BODY, DELUGE GENERATOR			
DATA RIGHT SIDE LADDER BRACKETS, 45' SIDE CONTROL			
P/N FOR PENNSAUKEN, NEW JERSEY			
MODEL PIERCE			
ENFORCER NO. 38420AD			