

**PUMPER
BODY**

Long Aluminum 2nd Gen Pumper

CHASSIS

Enforcer Chassis

**CHASSIS
AXLE, FRONT, CUSTOM**

19,500 Lb TAK-4 Axle

AXLE, REAR

27,000 Lb Meritor Axle

ENGINE

450 HP Cummins X10 Engine

TRANSMISSION

Allison 6th Gen, 3000 EVS P

BUMPER

22" Extended Painted Steel

CAB

7010 Enforcer Cab

BODY

WATER TANK

750 Gallon New York Style Water Tank

COMPT, PUMPER, REAR

30.75" FF RollUp Rear Compt

COMPT, PUMPER, LEFT SIDE

161" Lap Full Height & Depth Front & Rear

COMPT, PUMPER, RIGHT SIDE

161" Lap Low FDLER

**FIRE SUPPRESSION
PUMPHOUSE**

45" Control Zone Side Mount

PUMP

1500 GPM Waterous CSU

CROSSLAYS, 1.50"

(2) 1.50" Standard Capacity

CROSSLAYS, 2.50"

(1) 2.50" Standard Capacity

SPEEDLAYS

SpeedLays Not Required

GENERATOR

Generator Not Required

Foam System

Foam System Not Required

Foam Cell

Foam Cell Not Required

Side Roll and Frontal Impact Protection

NOTE

DIMENSIONS SHOWN ARE APPROXIMATE AND ARE SUBJECT TO MINOR DEVIATIONS AS MAY OCCUR OR BE NECESSARY IN CONSTRUCTION. MINOR DETAILS NOT SHOWN.

- ONE 1.50" OUTLET WITH 2.00" PIPING AND SWIVEL LOCATED IN CENTER BUMPER TRAY
- SHORELINE RECEPTACLE WITH KUSSMAUL SUPER AUTO-EJECT LOCATED ON DRIVER SIDE OF THE CAB
- AIR INLET WITH DISCONNECT COUPLING IN THE DRIVER SIDE STEPWELL
- BATTERY CHARGER LOCATED PER ORDER
- BATTERY CHARGE INDICATOR LOCATED ON THE DRIVER SIDE SEAT RISER
- ADJUSTABLE SHELVES LOCATED PER ORDER
- ONE FLOOR MOUNTED SLIDE-OUT TRAY LOCATED PER ORDER

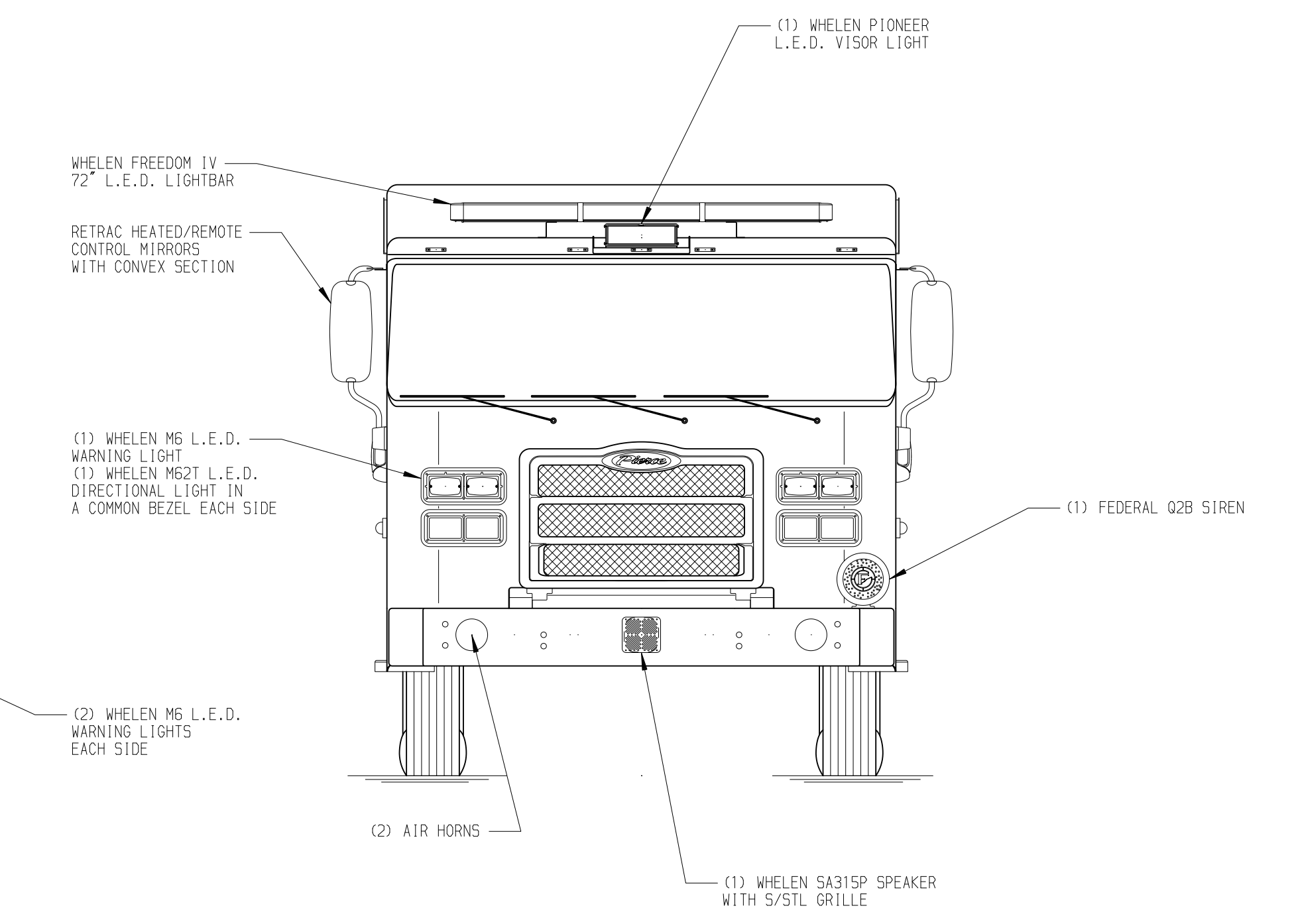
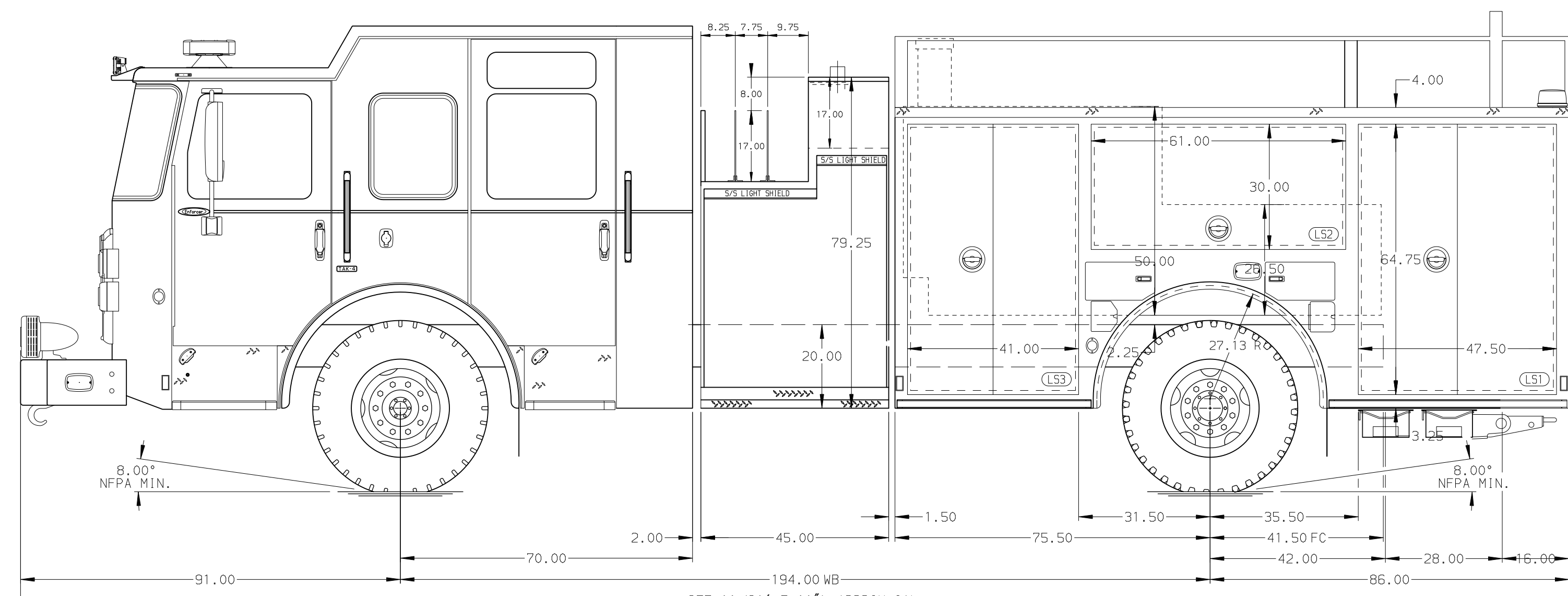
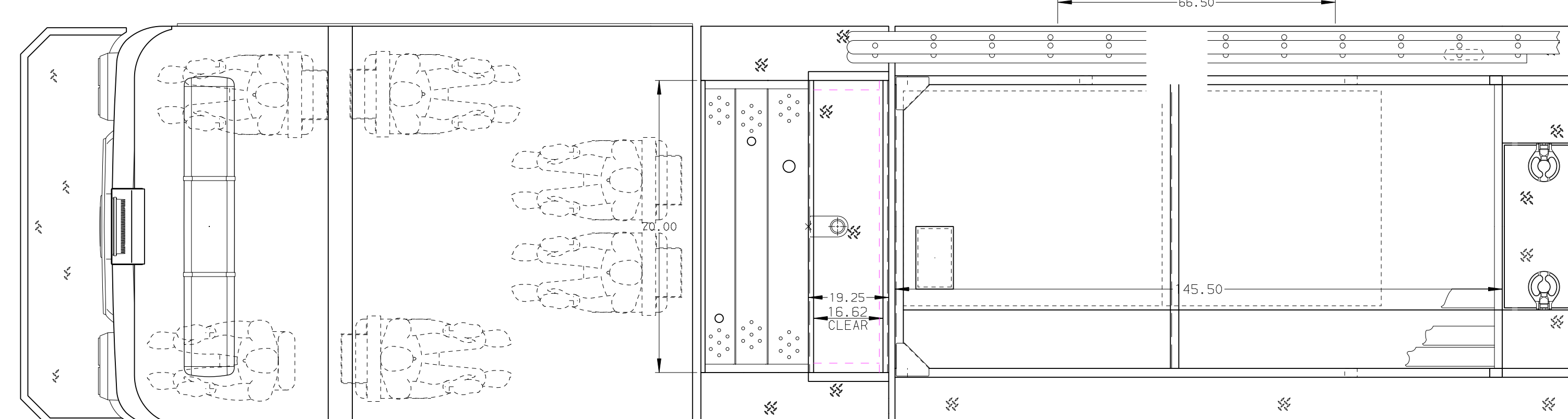
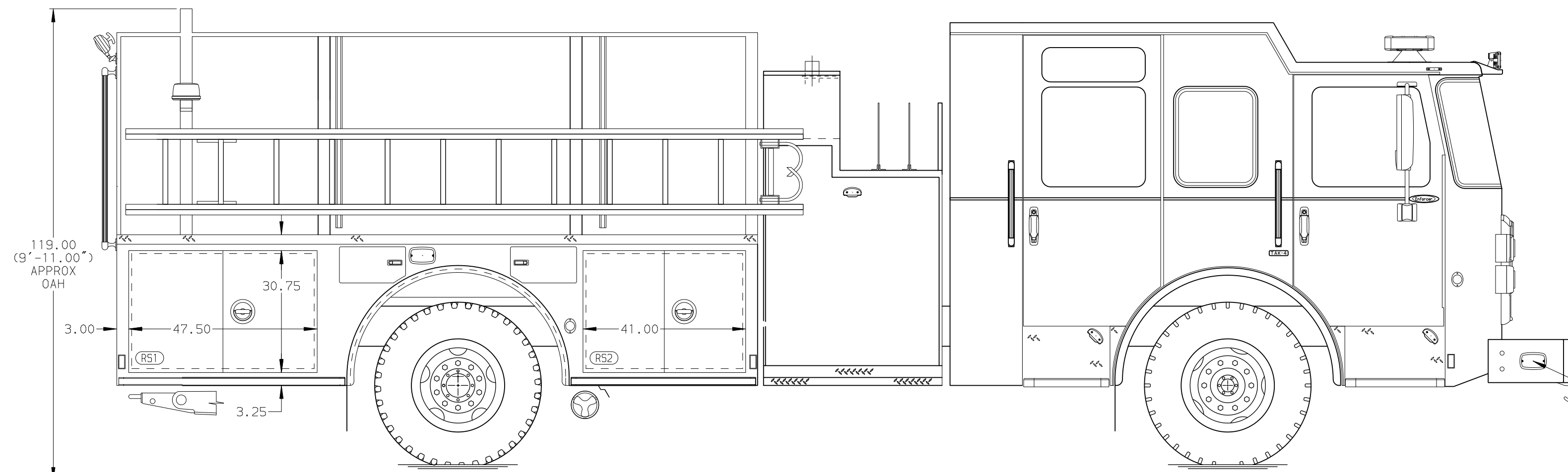

HOSEBED CAPACITY	
BED 1	1000' OF 5.00" D.J. POLY HOSE
BED 2	1000' OF 3.00" D.J. POLY HOSE

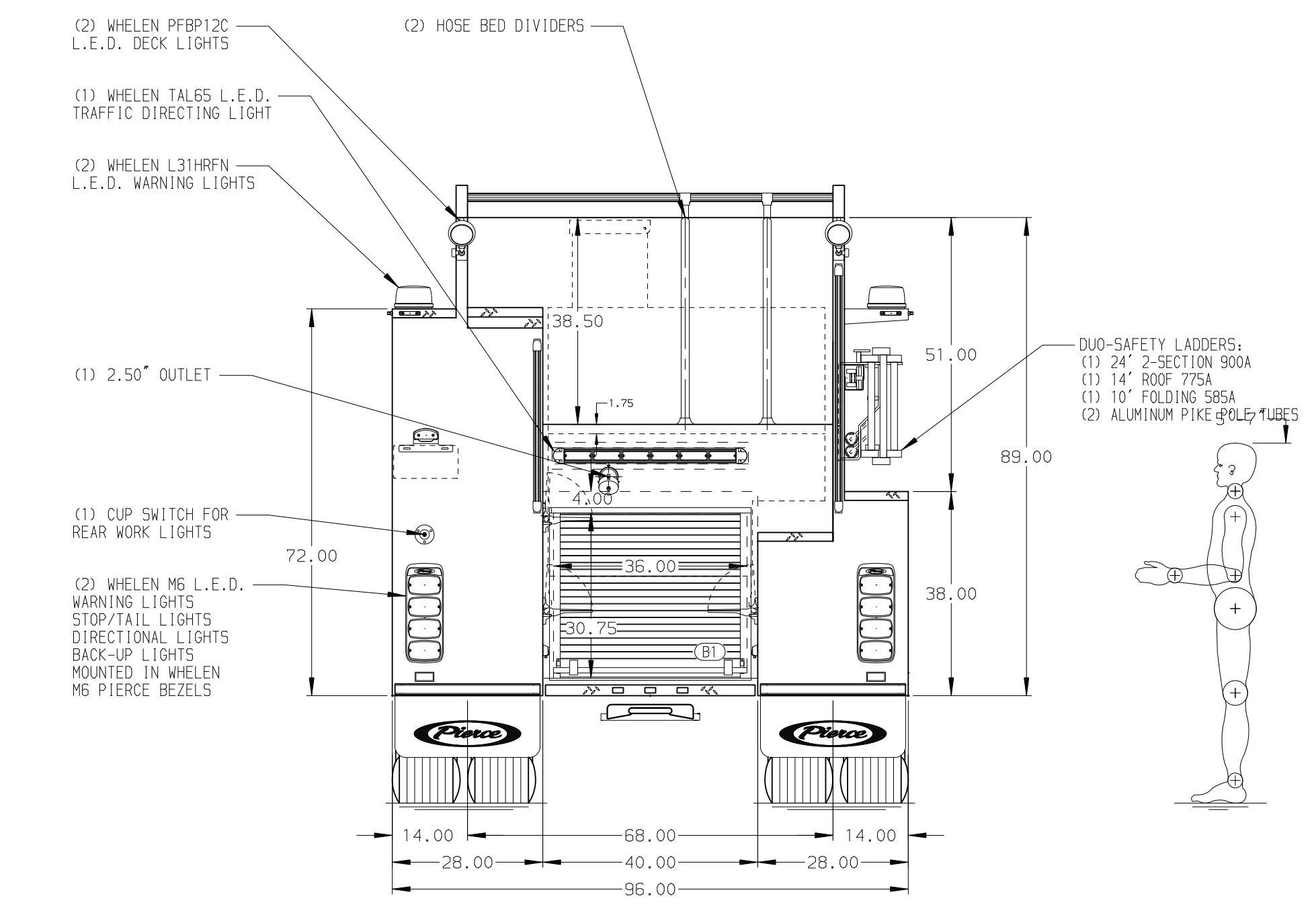

CUSTOMER APPROVAL

APPROVED BY: _____
DATE: _____

		JOB NO.	-
		SCALE	1:24 DATE
		DRAWN BY	-
		CHECKED BY	-
		SHEET SIZE	SHEET NO.
		D	1 OF 1

*****NOTE*****
INCOMPATIBLE ISSUE WITH THE DRAWING, PLEASE SEND DRAWING IN TO PIERCE FOR EVALUATION
INCOMPATIBILITY-05 REAR OUTLET-TRAFFIC DIRECTING LIGHT
FOLDING LADDER-PLEASE CHANGE MOUNTING TO BEHIND LADDERS ON LADDER BRACKETS
PIKE POLE TUBES-PLEASE CHANGE MOUNTING TO BEHIND LADDERS ON LADDER BRACKETS

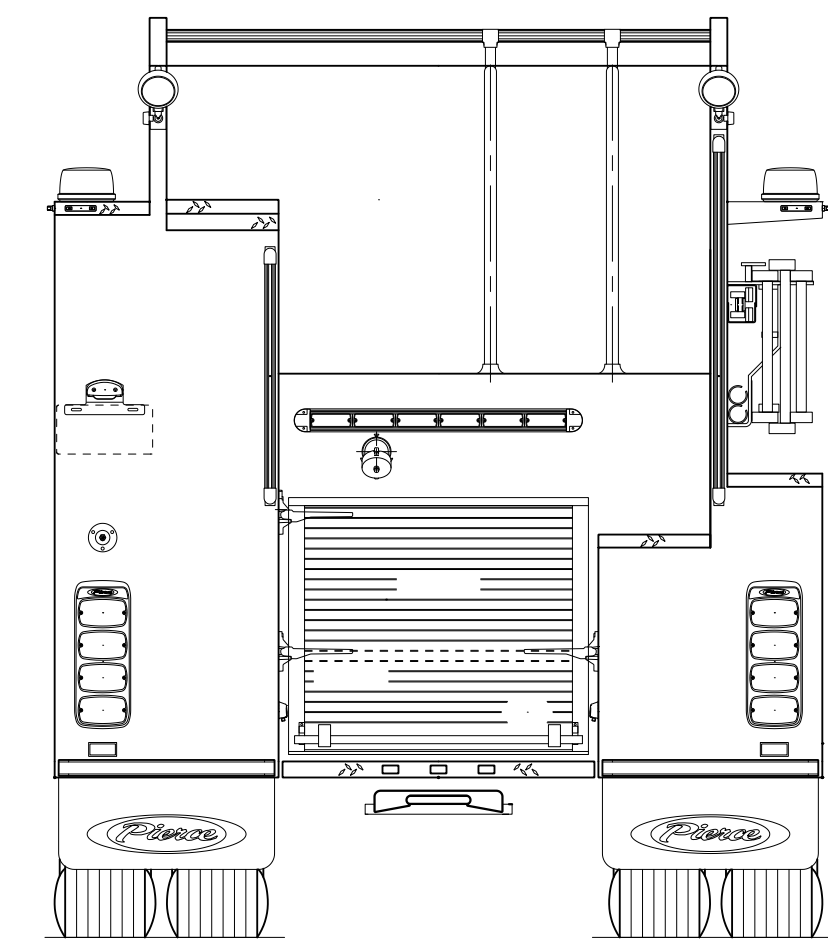
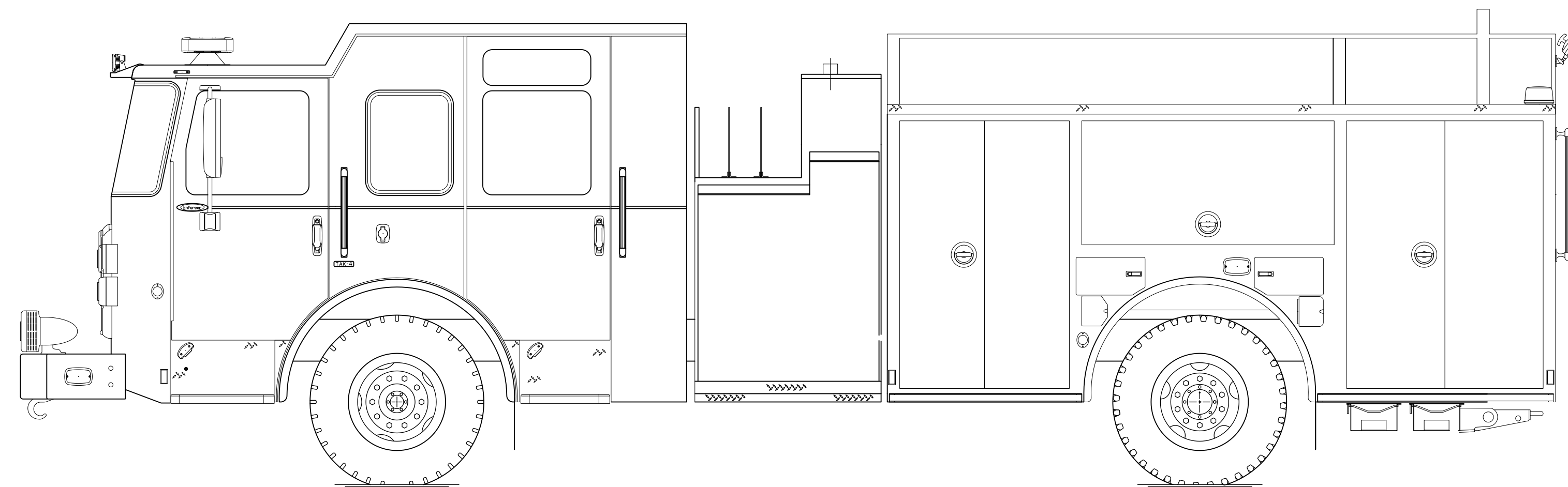
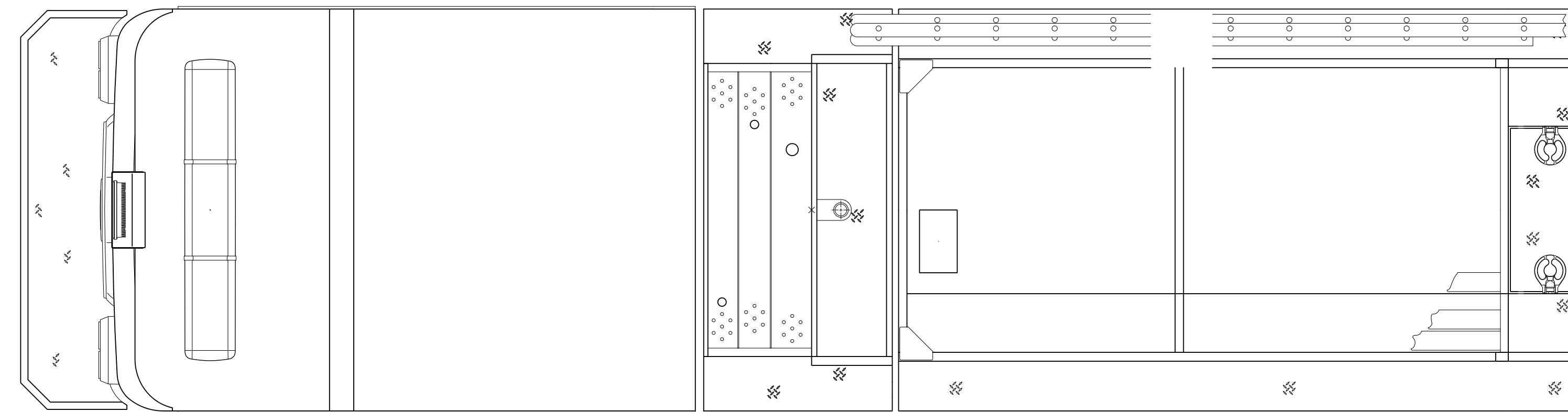
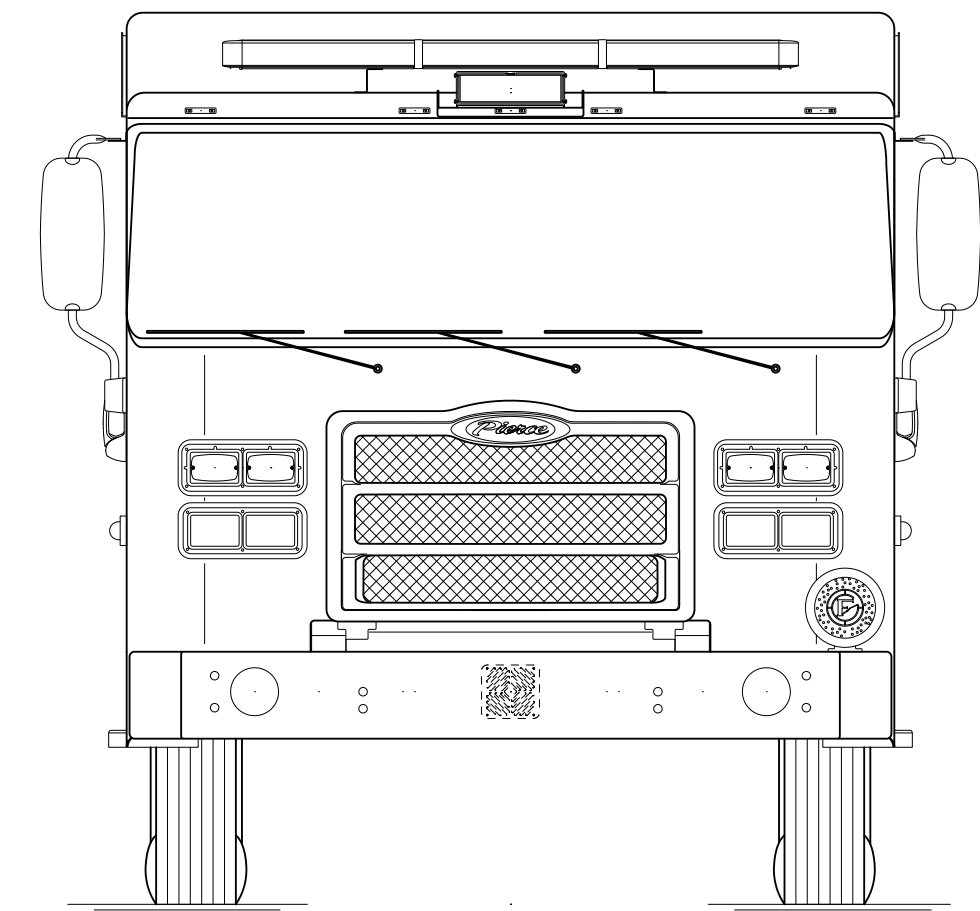
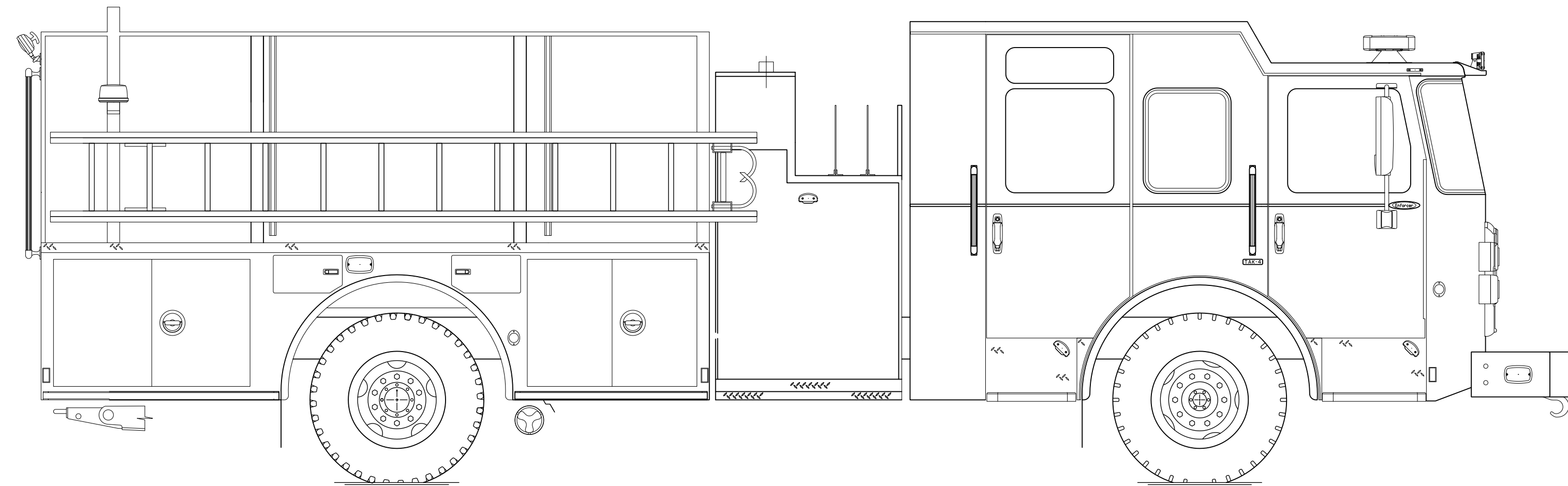

NOTE
LAYOUT AND SIZES PROVIDED BY CUSTOMERS
MAY VARY DUE TO AVAILABLE WORKING SPACE.

COLOR LEGEND	
PINK	LETTERING (VINYL OR REFLECTIVE)
ORANGE	STRIPING (VINYL OR REFLECTIVE)
GREEN	GOLD LEAF
YELLOW	CUSTOMER FURNISHED PRODUCT

CUSTOMER APPROVAL

APPROVED BY: _____
DATE: _____

REV	DATE	BY	CH



TITLE LETTERING, STRIPING, AND PAINTING INSTRUCTIONS
FOR DEMAREST FIRE DEPARTMENT
DWG NO. LSP-LP

JOB NO.	-
SCALE	1:24
DATE	
DRAWN BY	-
CHECKED BY	-
SHEET SIZE	D
SHEET NO.	1 of 1

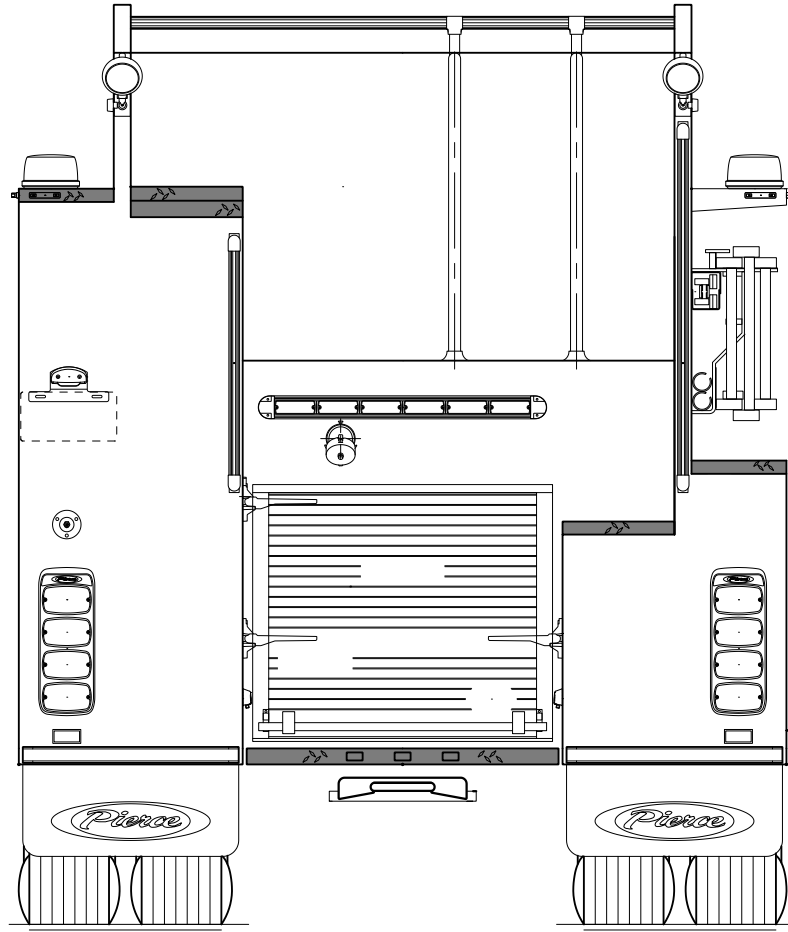

CUSTOMER APPROVAL

APPROVED BY: _____

DATE: _____

NOTE: PLEASE REVIEW CHEVRON COVERAGE AND DOOR MATERIAL PER PULSE OPTIONS. NON-RELATED OR NON-CRITICAL MINOR DEVIATIONS MAY EXIST.



MANUFACTURING INC.

JOB NO.

-

SCALE

1:24

DRAWN BY

-

DATE

14MAR23

TITLE

CHEVRON DRAWING

-

FOR

DEMAREST FIRE DEPARTMENT

-

DWG NO.

CHEVRON-CD

SHEET SIZE

A

SHEET NO.

1 OF 1