

**PUMPER
BODY**

Medium Aluminum 2nd Gen Pumper

CHASSIS

Enforcer Chassis

**CHASSIS
AXLE, FRONT, CUSTOM**

20,000 Lb Dana Axle

AXLE, REAR

27,000 Lb Dana Axle

ENGINE

450 HP Cummins L9 Engine

TRANSMISSION

Allison 5th Gen, 3000 EV5 P

BUMPER

19" Extended Stainless Steel

CAB

7010 Enforcer Cab

**BODY
WATER TANK**

750 Gallon New York Style Water Tank

COMPT, PUMPER, REAR

30.75" FF RollUp Rear Compt

COMPT, PUMPER, LEFT SIDE

152" Lap Full Height Front & Rear FDLER

COMPT, PUMPER, RIGHT SIDE

152" Lap Low FDLER

**FIRE SUPPRESSION
PUMPHOUSE**

52" Control Zone Side Mount

PUMP

2000 GPM HoLe QMAX-200

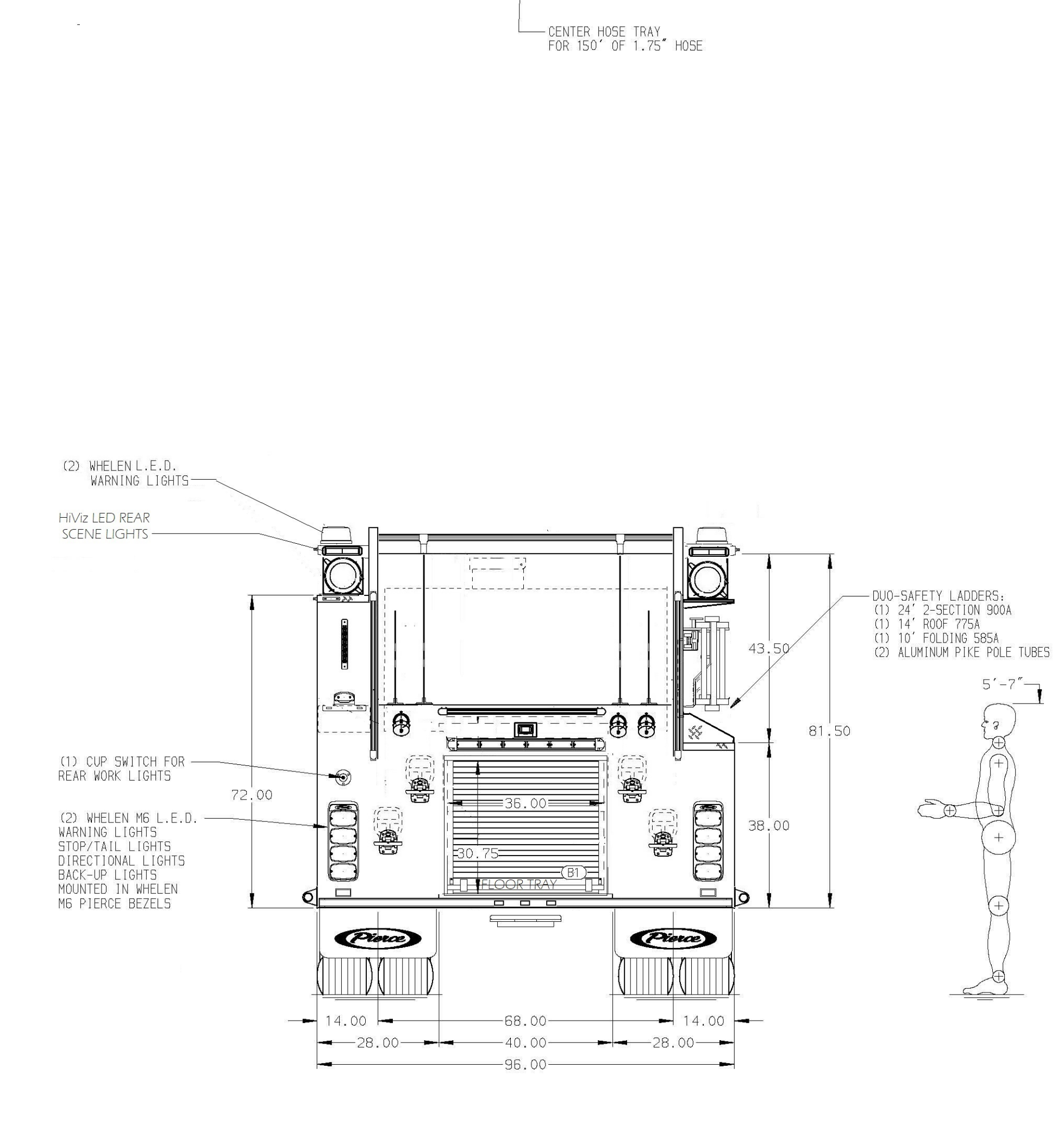
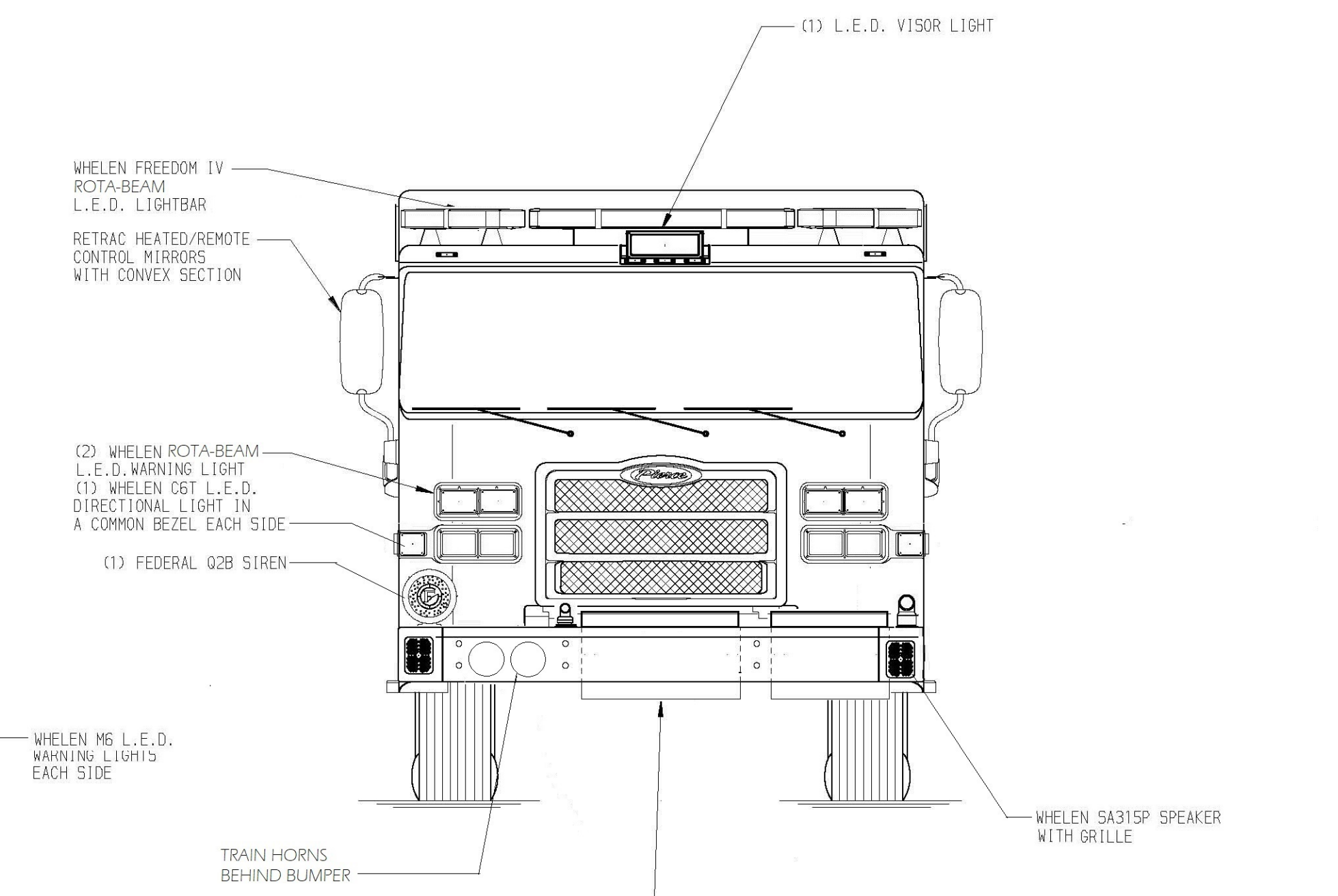
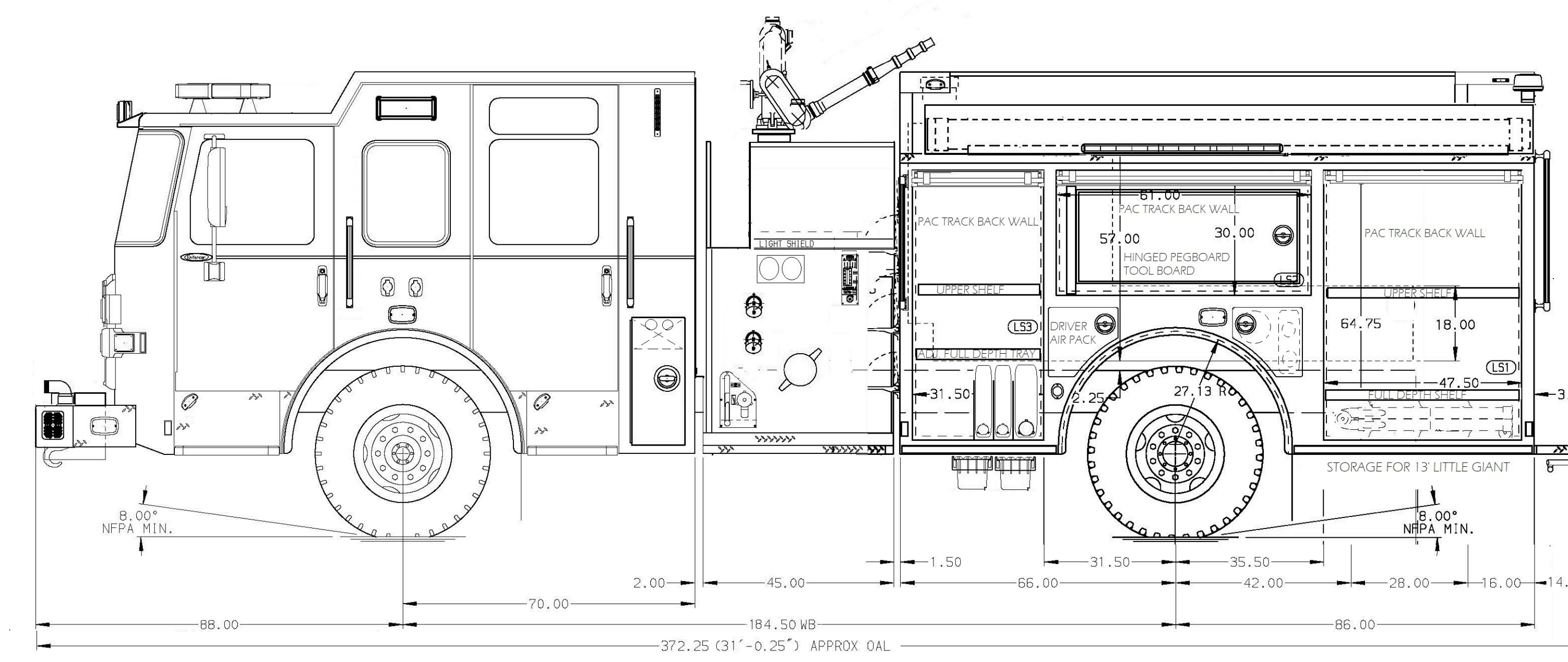
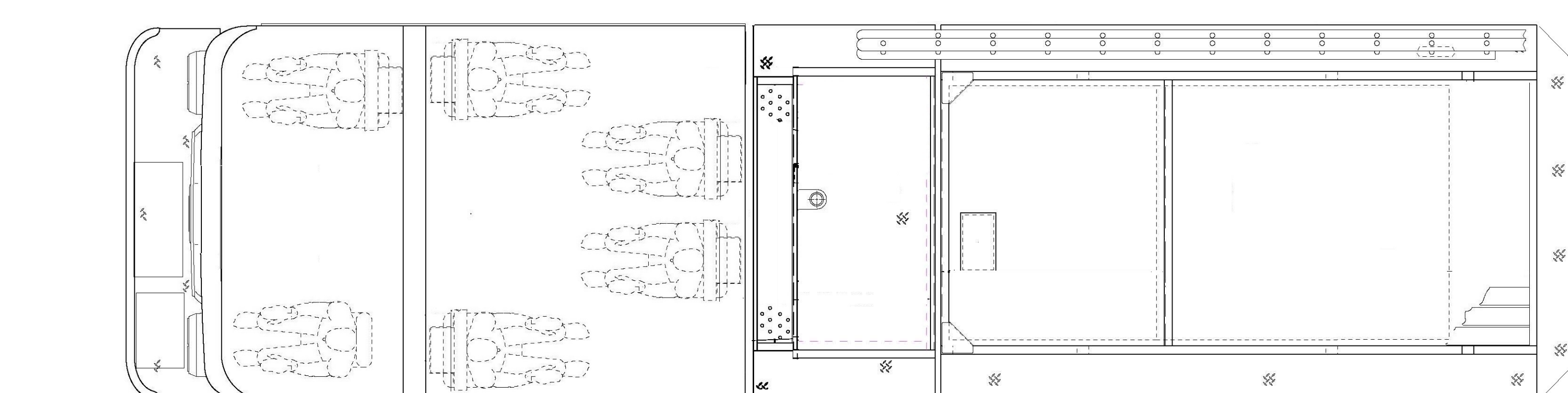
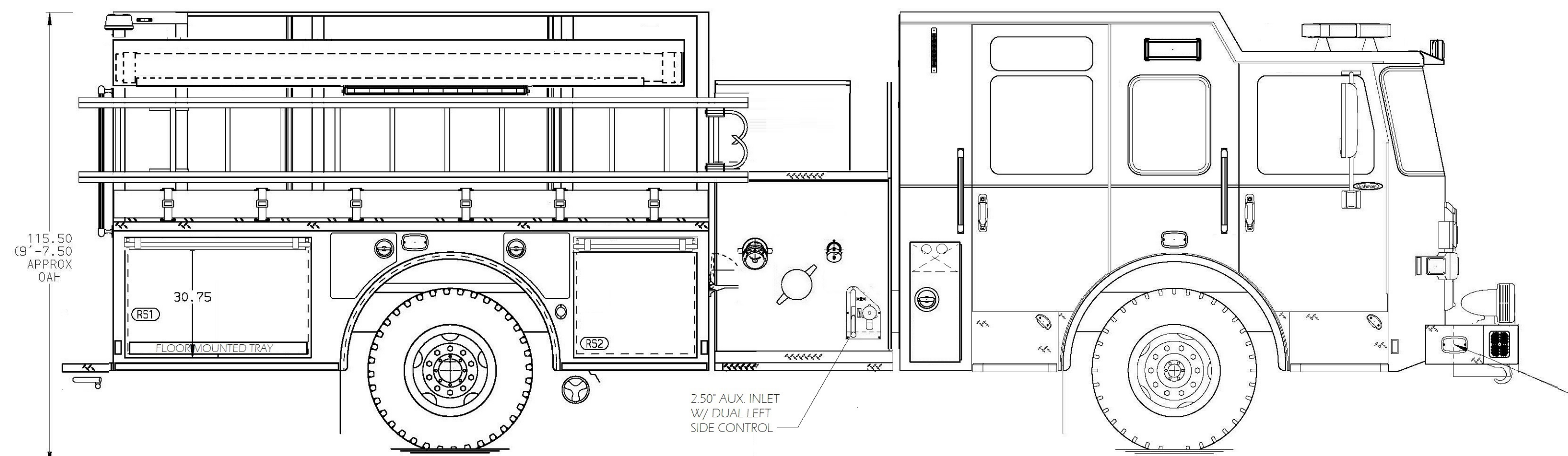

NOTE
DIMENSIONS SHOWN ARE APPROXIMATE AND ARE SUBJECT TO MINOR DEVIATIONS AS MAY OCCUR OR BE NECESSARY IN CONSTRUCTION. MINOR DETAILS NOT SHOWN.

CUSTOMER APPROVAL			
APPROVED BY:			
DATE:			
REV	DATE	BY	CH
B	122022	EET	
A	081922	EET	

		JOB NO.	-
PIERCE MANUFACTURING INC.		SCALE	1:24
TITLE PIERCE ENFORCER 2000 GPM PUMPER, 750 NY STYLE WATER TANK, REAR DISCHARGES, ENCLOSED SUCTION HOSE STORAGE,		DATE	
MAKE PIERCE		DRAWN BY	EET
MODEL ENFORCER		CHECKED BY	-
FOR CLINTON TOWNSHIP FIRE DEPARTMENT ANNANDALE, NEW JERSEY		SHEET SIZE	D
DWG NO. PRELIMINARY DRAWING		SHEET NO.	1 OF 1