

STORAGE COMPARTMENT TO CONTAIN THE FOLLOWING EQUIPMENT:
 (1) 40" DUO-SAFETY 2-SEC 1525-A
 (1) 35" DUO-SAFETY 2-SEC 1200-A
 (1) 28" DUO-SAFETY 2-SEC 1200-A
 (1) 20" DUO-SAFETY 2-SEC 900-A
 (1) 20" DUO-SAFETY ROOF 875-A
 (1) 10" DUO-SAFETY FOLDING 585-A
 (5) PIKE POLE TUBES

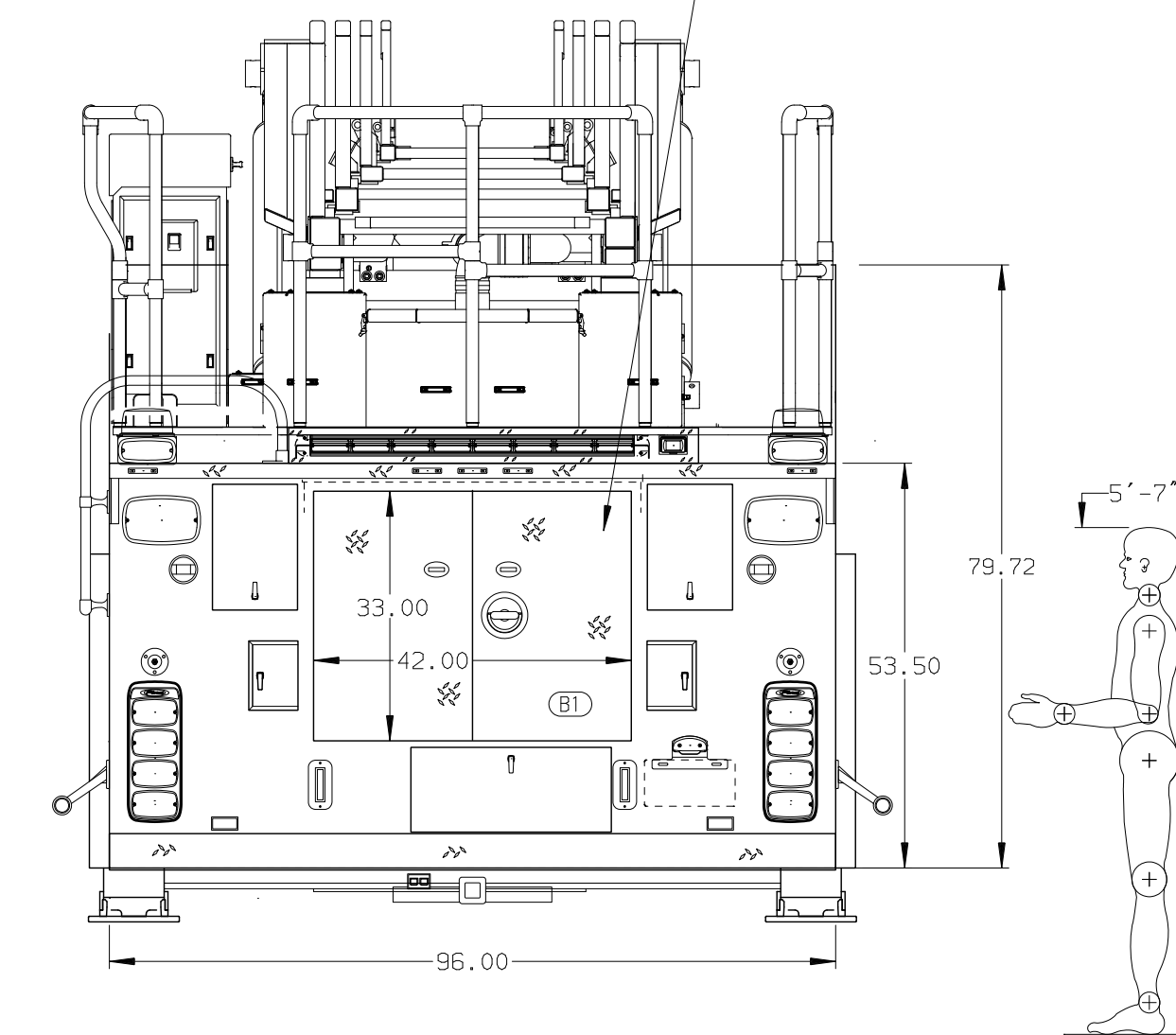

ALUMINUM BODY

MAX O.A.H. 11'-6.00"

SIDE ROLL AND FRONTAL IMPACT PROTECTION

NOTE
 DIMENSIONS SHOWN ARE APPROXIMATE AND ARE SUBJECT TO MINOR DEVIATIONS AS MAY OCCUR OR BE NECESSARY IN CONSTRUCTION. MINOR DETAILS NOT SHOWN.

1. AERIAL PEDESTAL LOWERED 1.00"

REV	DATE	BY	CH	VELOCITY
26JUL22	NDA	-		
28JUN22	LWE	NDA		

		JOB NO.	PRELIM
		SCALE	DATE
TITLE	100' AERIAL LADDER AND BODY ASSEMBLY	DRAWN BY	NDA
FOR	300 GALLON WATER TANK	CHECKED BY	CRI
	CHERRY HILL FIRE DISTRICT 13	SHEET SIZE	D
	FIRE & SAFETY SERVICES, LTD.		
DWG NO.	05-0379		