

- RIGHT SIDE COMPARTMENTS CONTAIN THE FOLLOWING:**
- COMPARTMENT R51 CONTAINS:
 - (1) VERTICAL COMPARTMENT DIVIDER
 - (2) SPECIAL DEPTH ADJ SHELVES
 - (6) 6000 UN AIR STORAGE BOTTLES
 - (1) 1" LIP ON COMPARTMENT FLOOR
 - COMPARTMENT R52 CONTAINS:
 - (1) VERTICAL COMPARTMENT DIVIDER
 - (1) STD DEPTH ADJ SLIDE OUT/TILT TRAY
 - COMPARTMENT R53 CONTAINS:
 - (1) FLOOR MOUNTED TRAY W/TOOLBOARD
 - (1) 20A, 120V 6-PLACE RECEPTACLE STRIP
 - (1) LOW PRESSURE TOOL AIR REEL WITH 150' OF HOSE
 - (1) SLIDE OUT ROLLER GUIDE
 - (1) LOW PRESSURE TOOL AIR CONTROL PANEL
 - COMPARTMENT R54 CONTAINS:
 - (1) STD DEPTH ADJ SHELF
 - (1) #750 FLOOR MOUNTED TRAY
 - (1) FLOOR MOUNTED TRAY
 - (1) 3/8" ADJUSTABLE PLATE
 - (1) 15/20A, 120V DUPLEX RECEPTACLE
 - COMPARTMENT R55 CONTAINS:
 - (1) VERTICAL COMPARTMENT DIVIDER
 - (3) STD DEPTH ADJ SHELVES
 - (1) STD DEPTH ADJ SLIDE OUT/TILT TRAY
 - (1) FLOOR MOUNTED TRAY
 - (1) 15/20A, 120V DUPLEX RECEPTACLE
 - (1) SLIDE OUT ROLLER GUIDE
 - (1) ELECTRIC CORD REEL WITH 200' OF 10/4 YELLOW CORD
 - COMPARTMENT R56 CONTAINS:
 - (1) VERTICAL COMPARTMENT DIVIDER
 - (1) STD DEPTH ADJ SLIDE OUT/TILT TRAY
 - (1) FLOOR MOUNTED TRAY
 - (1) 15/20A, 120V DUPLEX RECEPTACLE
 - (1) SLIDE OUT ROLLER GUIDE
 - (1) ELECTRIC CORD REEL WITH 200' OF 10/4 YELLOW CORD

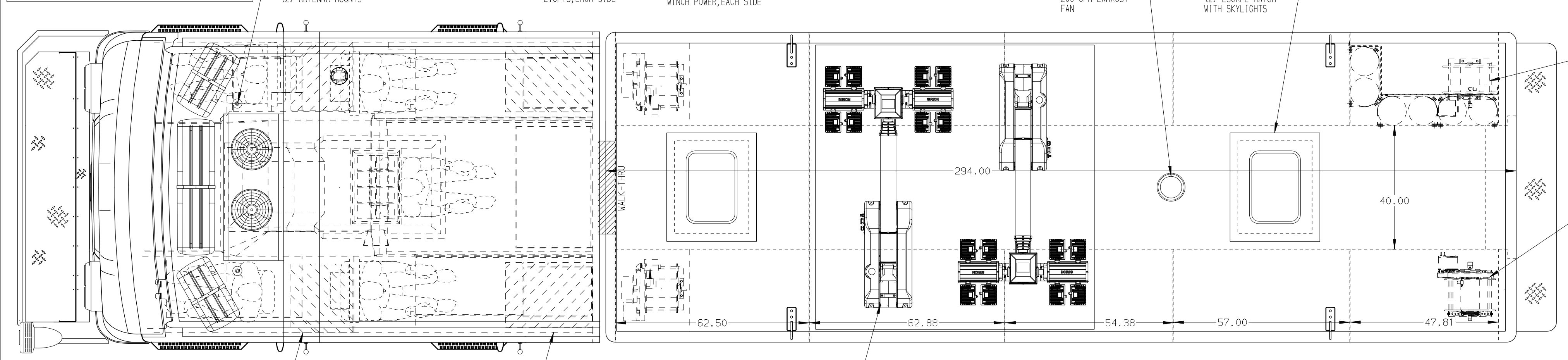

- LEFT SIDE COMPARTMENTS CONTAIN THE FOLLOWING:**
- COMPARTMENT L51 CONTAINS:
 - (1) REMOVABLE AWNING
 - (1) FLOOR MOUNTED TRAY
 - (2) NIGHTSCAN CONTROLLERS
 - (1) 3/8" ADJUSTABLE PLATE
 - (1) 15/20A, 120V DUPLEX RECEPTACLE
 - (1) CASCADE SYSTEM CONTROL PANEL
 - (1) "SPACESAVER" 2-BOTTLE FILL ENCLOSURE
 - (1) BREATHING AIR BOOSTER PUMP
 - COMPARTMENT L52 CONTAINS:
 - (1) STD DEPTH ADJ SLIDE OUT/TILT TRAY
 - TEXTURED PLASTIC FLOORING IN COMPARTMENT
 - (1) 15/20A, 120V DUPLEX RECEPTACLE
 - COMPARTMENT L53 CONTAINS:
 - (2) 3/8" ADJUSTABLE PLATES
 - COMPARTMENT L54 CONTAINS:
 - (4) ON-SCENE SLIDE OUT TOOLBOARDS W/TRAYS
 - COMPARTMENT L55 CONTAINS:
 - (1) ON SCENE SLIDE OUT TOOLBOARD W/TRAY
 - (1) CIRCUIT BREAKER PANEL
 - (1) GENERATOR METER PANEL
 - (1) SUB FEED BOX
 - (1) 7-DRAWER C-TECH CABINET
 - (1) VERTICAL COMPARTMENT DIVIDER
 - (1) STD DEPTH ADJ SHELF
 - (1) ELECTRIC CORD REEL WITH 200' OF 10/4 YELLOW CORD
 - (1) SLIDE OUT ROLLER GUIDE
 - COMPARTMENT L56 CONTAINS:
 - (2) ADJUSTABLE SHELVES

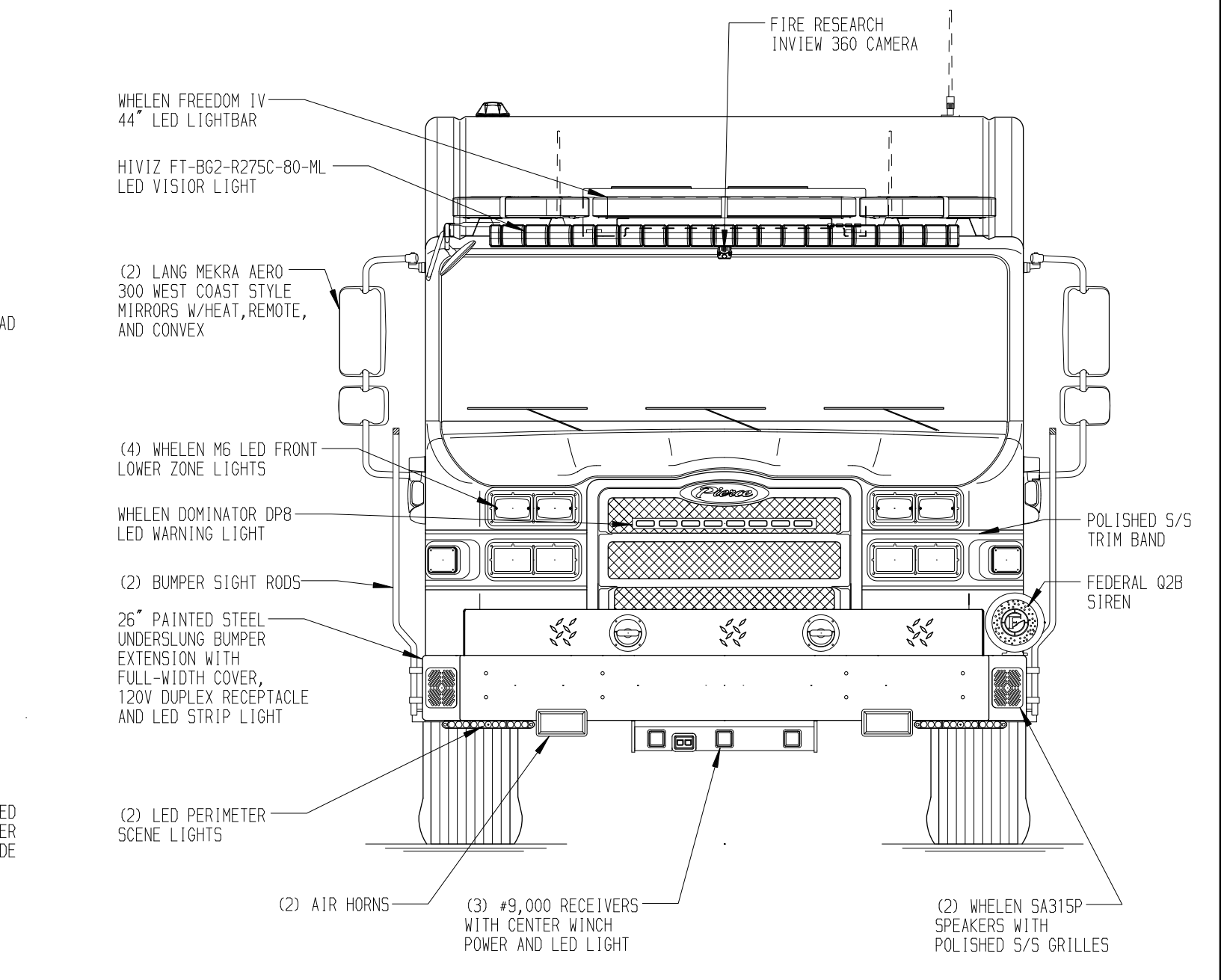
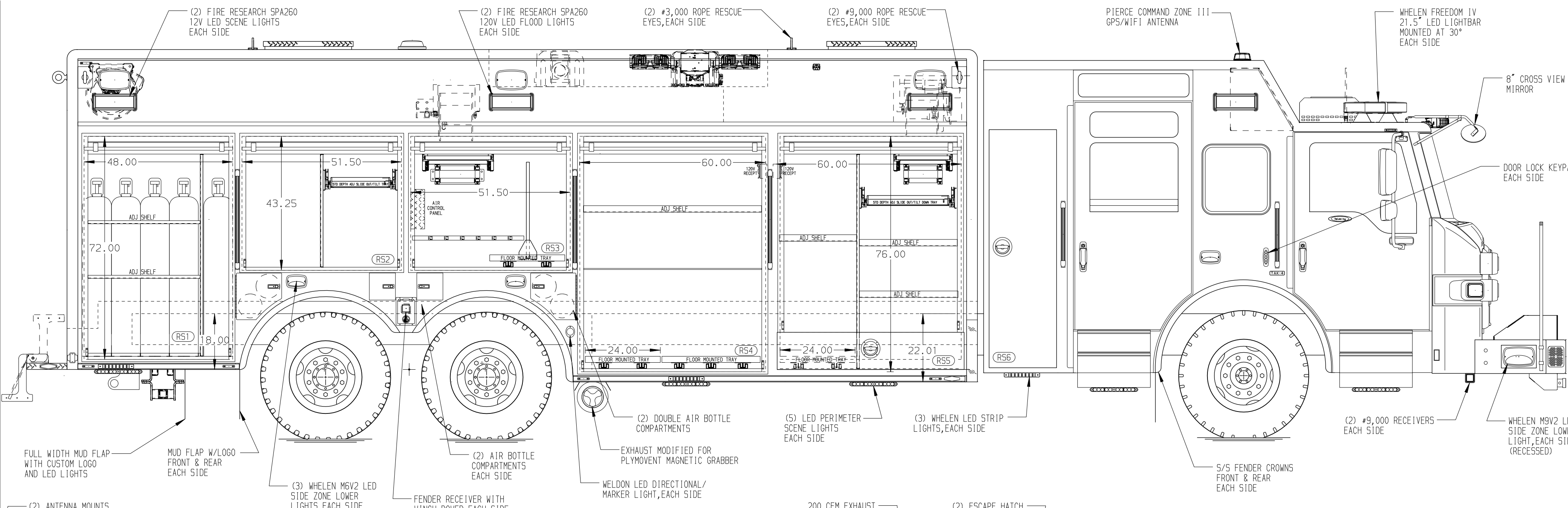
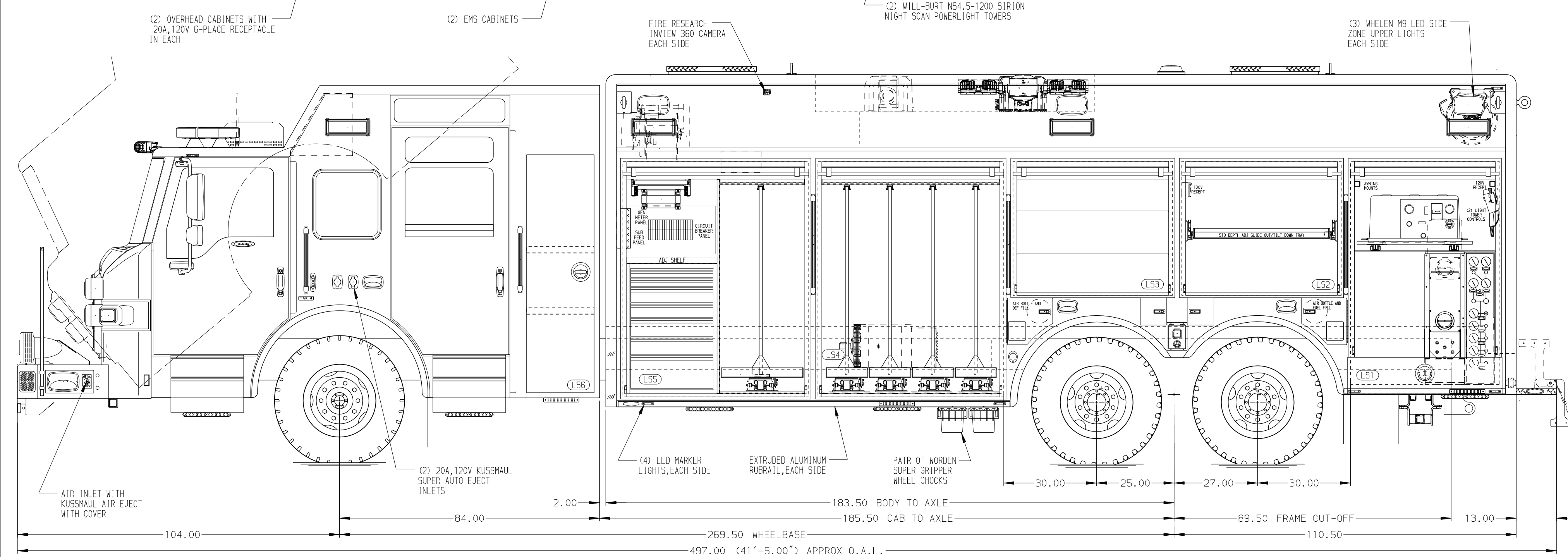
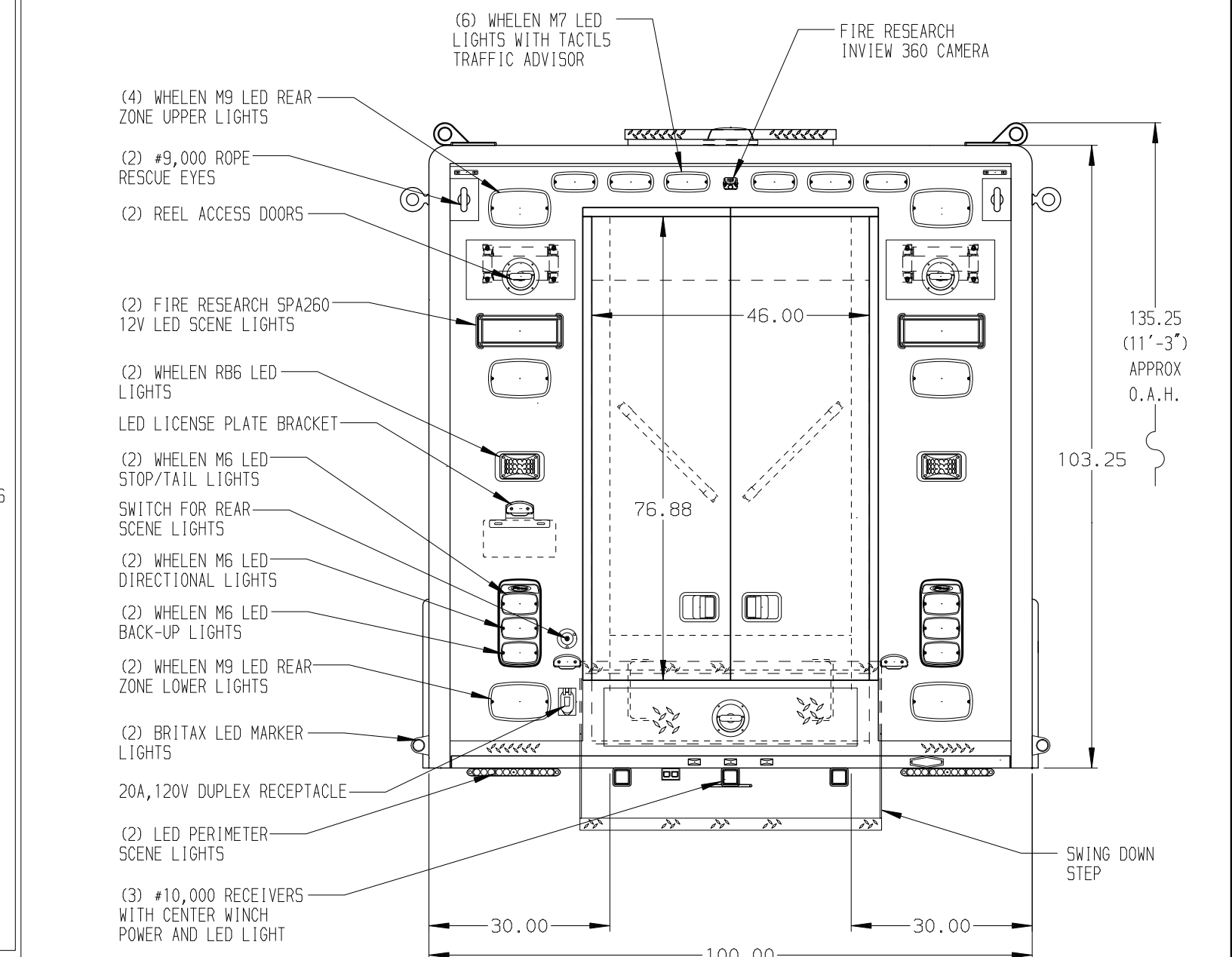

NOTE
DIMENSIONS SHOWN ARE APPROXIMATE AND ARE SUBJECT TO MINOR DEVIATIONS AS MAY OCCUR OR BE NECESSARY IN CONSTRUCTION. MINOR DETAILS NOT SHOWN.

- NOTES:**
- ONAN 35kW SINGLE PHASE PTO DRIVEN GENERATOR WITH SPLASH GUARD LOCATED BETWEEN THE FRAME RAILS
 - (4) #9,000 PINNABLE ROPE ANCHORS
 - WARN #5,000 PORTABLE RECEIVER STYLE WINCH
 - POLISHED 5/5 SCUFFPLATES ON CAB AND CREW CAB DOOR JAMBS
 - FLOOR IN CAB AND CREW CAB TO BE PADDED RUBBER
 - KUSSMAUL 1200 CHARGER LOCATED BEHIND THE DRIVER'S SEAT
 - BATTERY CHARGE INDICATOR LOCATED ON DRIVER'S SEAT WITH BRACKET
 - 5/5 ON FRONT BODY CORNERS 20" HIGH
 - PIERCE LED LIGHT STRIPS IN ALL EXTERIOR BODY COMPARTMENTS
 - ROLL-OUT VINYL FLAP FOR COMPARTMENTS L52 AND R52 TO PROTECT FENDER PANEL
 - COMPARTMENT VENTILATION SYSTEM
 - 20A, 120V 6-PLACE RECEPTACLE LOCATED IN DRIVER'S SIDE EMS CABINET

CLEAR DOOR WIDTH KEY

AMDR ROLL UP DOORS:	-2 1/4"	29JUL22	DHE	AZU	CHASSIS DATA
GORTITE ROLL UP DOORS:	-2 1/2"	14JUN22	DHE	AZU	MAKE
PIERCE DOUBLE LAP DOORS:	-4 1/4"	10JUN22	DHE	AZU	PIERCE
PIERCE LIFT-UP LAP DOORS:	-1 1/2"	31MAR22	DHE	AZU	MODEL

(EX: 60" F-F - 2 1/4" = 57 3/4" CLEAR)
(F-F) = FRAME TO FRAME

REV DATE BY CH VXF82420

TITLE	HEAVY DUTY RESCUE WALKIN
FOR	PRINCETON FIRST AID AND RESCUE SQUAD BRID #406
DWG NO.	37204AD-SH1

Pierce MANUFACTURING INC.

JOB NO. 37204

SCALE 1:24 DATE

DRAWN BY DHE 23MAR22

CHECKED BY AZU 24MAR22

BY KEVIN DRISCOLL

SHEET SIZE D SHEET NO. 1 OF 1

(SIDE ROLL & FRONTAL IMPACT PROTECTION)