



Pierce Enforcer 75' Steel Ladder
City of Vineland
Job #36336

FEATURES & SPECIFICATIONS

- Pierce Enforcer 70" Chassis with a Flat Roof
- Cummins L9 450hp 2021 EPA Compliant Engine
- Allison EVS30000P Automatic Transmission
- Dana Front and Meritor Rear Axles
- Hale QMAX 2000 GPM Single Stage Pump
- 500 Gallon Poly Water Tank
- Delivered in August 2022



FIRE & SAFETY SERVICES, LTD.
South Plainfield, NJ
web: www.f-ss.com · phone: 800-400-8017

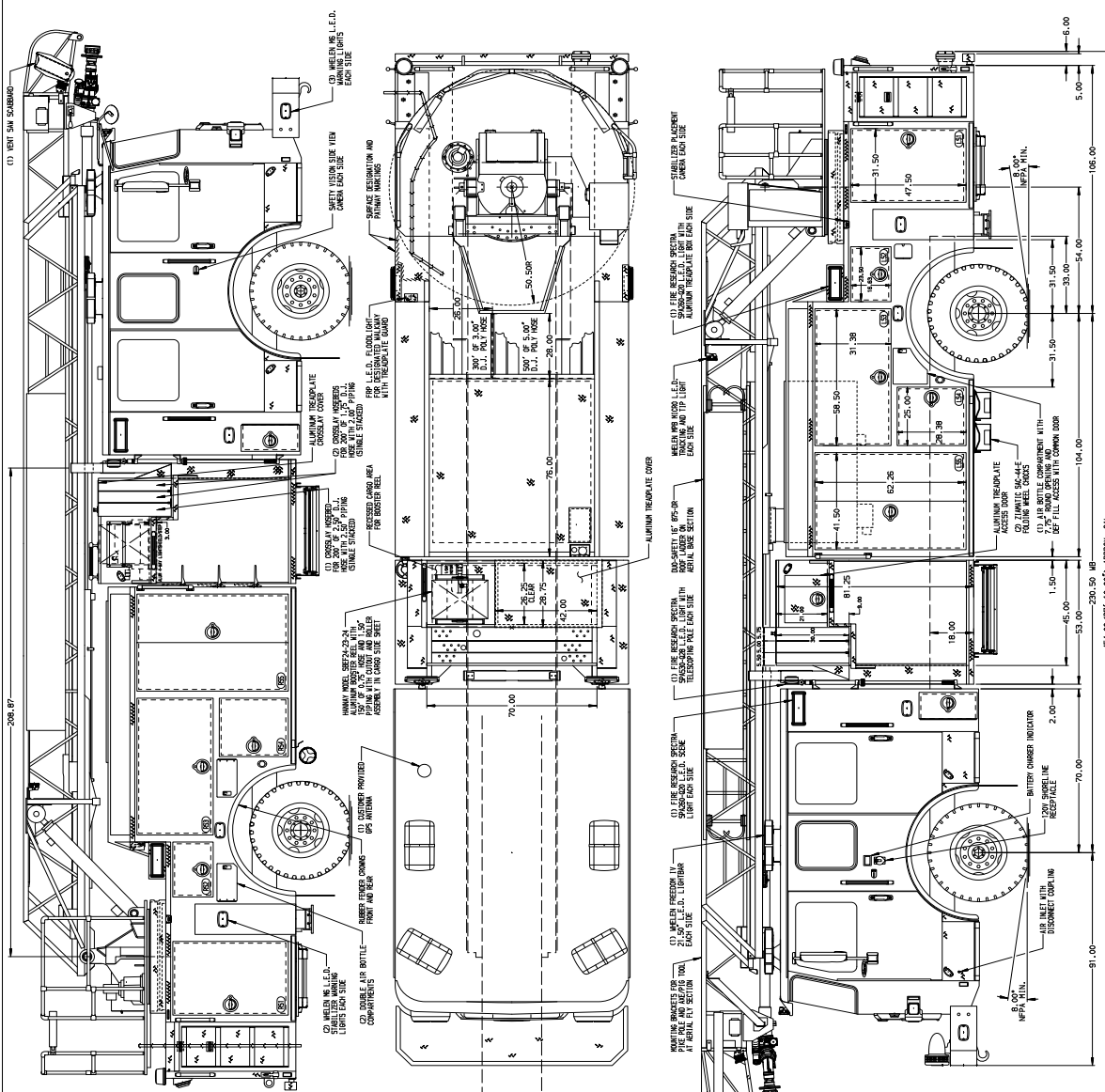

ALUMINUM BODY

NOTE
 DIMENSIONS SHOWN ARE APPROXIMATE AND ARE SUBJECT TO MINOR DEVIATIONS AS MAY OCCUR OR BE NECESSARY IN CONSTRUCTION.
 MINOR DETAILS NOT SHOWN.

- 1. BATTERY COMPARTMENT LOCATED BEHIND REAR WHEEL SHIRT.
- 2. BATTERY COMPARTMENT COVER LOCATED AT REAR OF BODY.
- 3. BATTERY COMPARTMENT COVER LOCATED AT REAR OF BODY.
- 4. BATTERY COMPARTMENT COVER LOCATED AT REAR OF BODY.
- 5. BATTERY COMPARTMENT COVER LOCATED AT REAR OF BODY.
- 6. BATTERY COMPARTMENT COVER LOCATED AT REAR OF BODY.
- 7. BATTERY COMPARTMENT COVER LOCATED AT REAR OF BODY.
- 8. BATTERY COMPARTMENT COVER LOCATED AT REAR OF BODY.
- 9. BATTERY COMPARTMENT COVER LOCATED AT REAR OF BODY.
- 10. BATTERY COMPARTMENT COVER LOCATED AT REAR OF BODY.

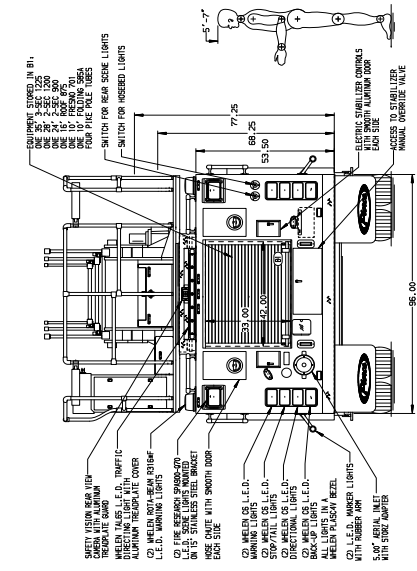
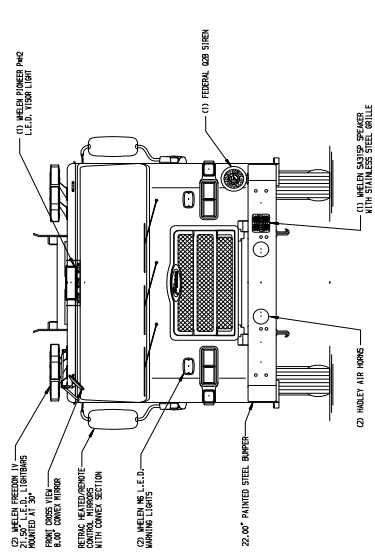

MANUFACTURING INC.	JOB NO. 36336	SCALE 1:1	DATE 11/24
Pierce	Drawn BY SHU	17AUG21	17AUG21
	Checked BY ZCH	18AUG21	18AUG21
	Model DNG	Sheet Size D	Sheet No. 1 OF 1
	Enforcer No. 36336AD		

CHASSIS DATA
 TITLE 75' HSL AERIAL LADDER AND BODY ASSEMBLY
 MAKE PIERCE
 MODEL DNG
 CITY OF VINELAND, NJ
 FOR VINELAND, NJ

REV
 18/08/21
 20/06/21

BY
 SHU
 ZCH

DATE
 17AUG21
 18AUG21