



**Skeeter High Water Rescue Truck**  
Somerset County Prosecutor's Office  
Job #2538

**FEATURES & SPECIFICATIONS**

- Freightliner M2 106 4x4 4-Door Chassis
- Cummins L9 300hp Diesel Engine
- Allison EVS3000 Automatic Transmission
- Side Step Entrance
- Rear Hydraulic Lift Gate with hand rails and wheel chair locks
- Wheel chair locks in center aisle of rear seating area
- Two (2) rows bench seats with storage underneath
- Delivered February 2022



**FIRE & SAFETY SERVICES, LTD.**

South Plainfield, NJ

web: [www.f-ss.com](http://www.f-ss.com) · phone: 800-400-8017

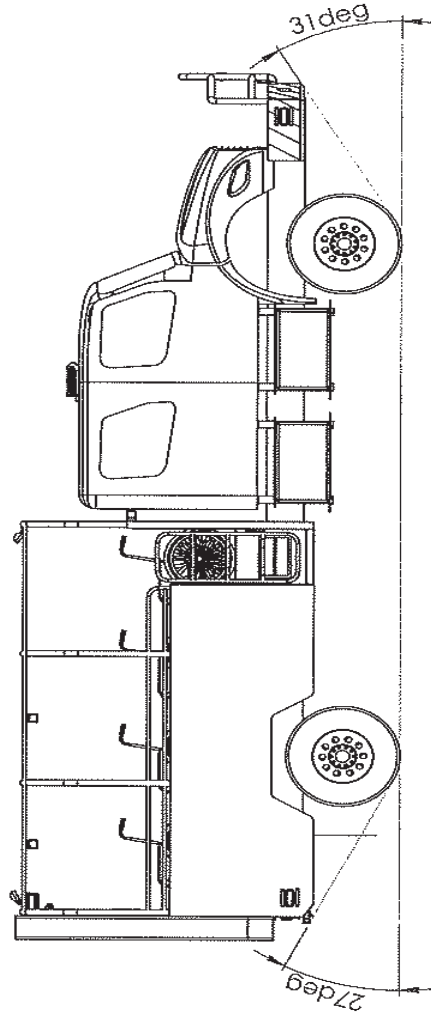
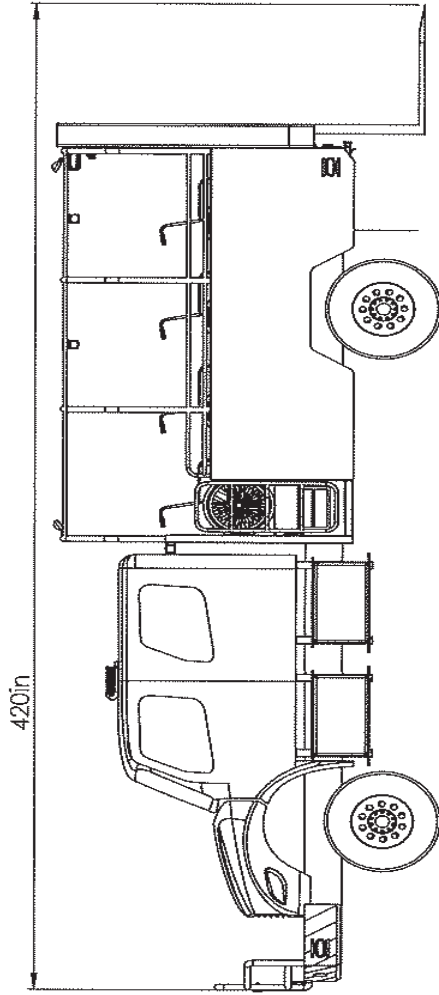
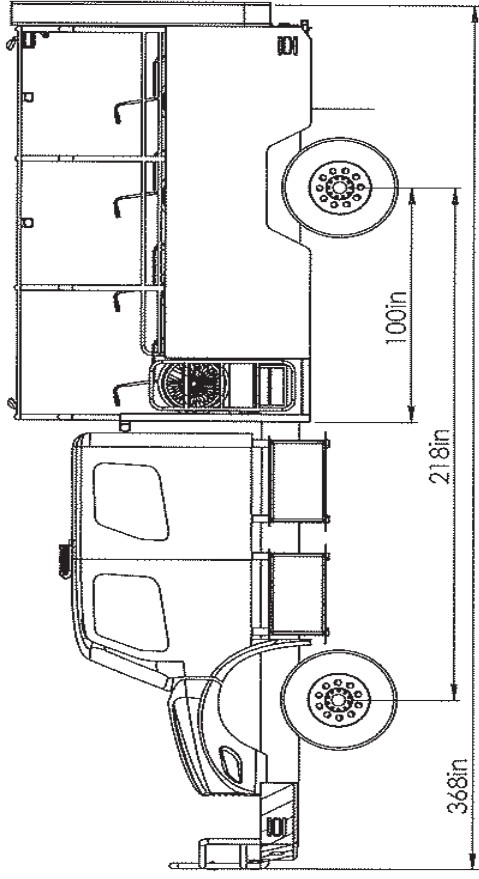
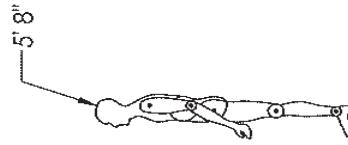
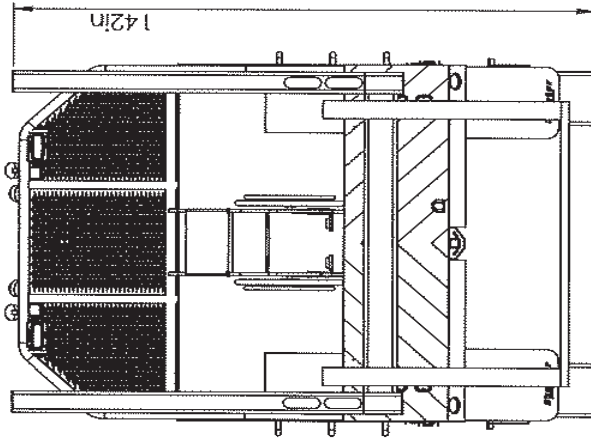
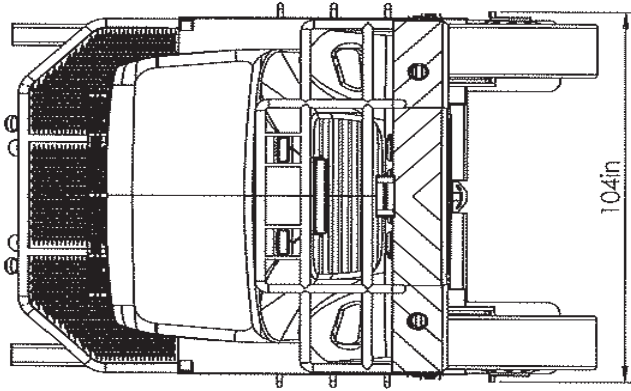

PROPERTY OF  
**SKEETER BRUSH TRUCKS**

NOTE: DETAILS AND DIMENSIONS SHOWN ARE APPROXIMATE  
AND ARE SUBJECT TO MINOR DEVIATIONS AS MAY  
OCCUR OR BE NECESSARY IN CONSTRUCTION  
MINOR DETAILS NOT SHOWN

PREPARED FOR:  
**Skeeter High Water Rescue**

DRAWN BY: MARK E.  
PRINT DATE: 3/27/2018

TITLE:

OVERALL DIMENSIONS

JOB NO. 14396

SHEET 11 OF 13