



Pierce Enforcer Pumper
Borough of Midland Park
Job #36040

FEATURES & SPECIFICATIONS

- Pierce Enforcer 84" Chassis with a 10" Raised Roof
- Cummins L9 450hp 2021 EPA compliant Engine
- Allison EVS3000P Automatic Transmission
- Meritor Front and Dana Rear Axles
- Waterous CsU 1500 GPM Single Stage Pump
- 500 Gallon "New York Style" Poly Water Tank
- Delivered in November 2021



FIRE & SAFETY SERVICES, LTD.

South Plainfield, NJ

web: www.f-ss.com · phone: 800-400-8017

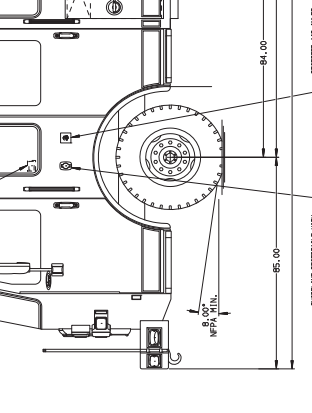
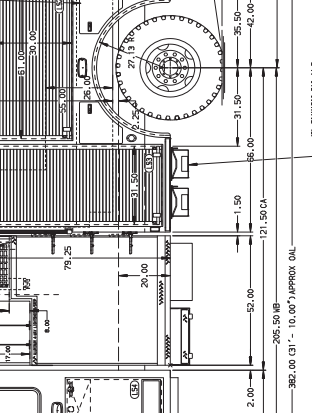
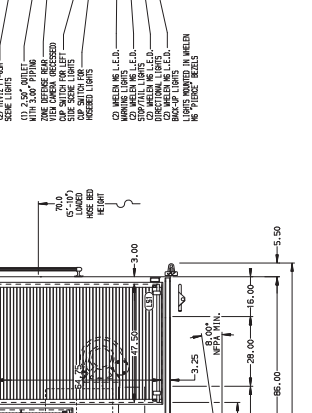
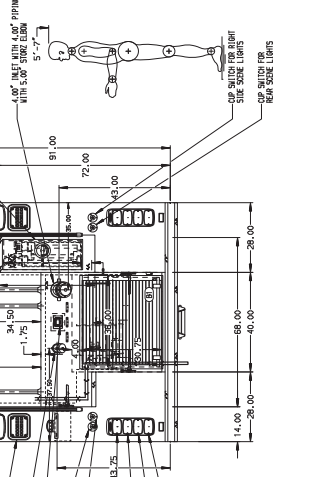
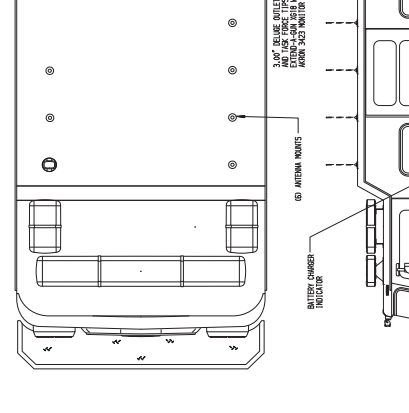
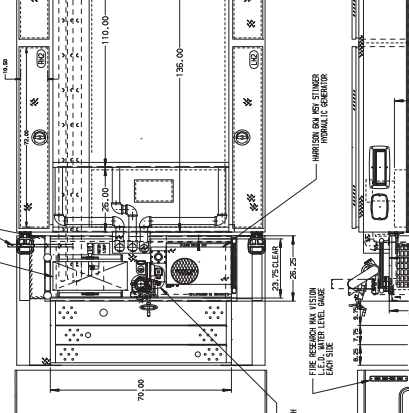
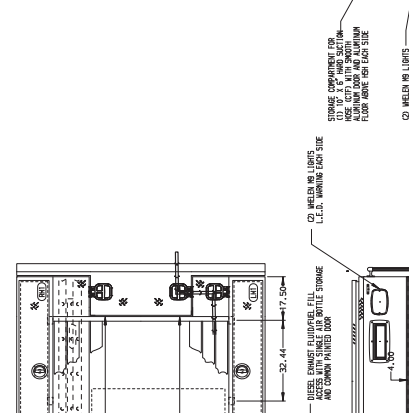
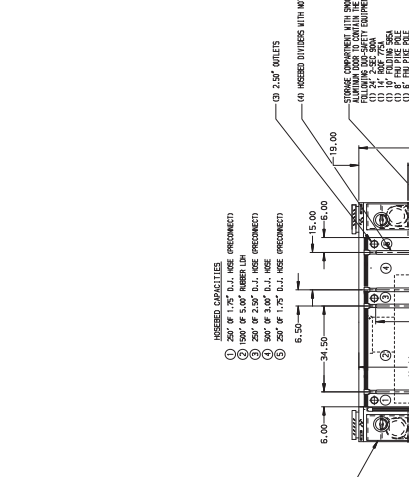
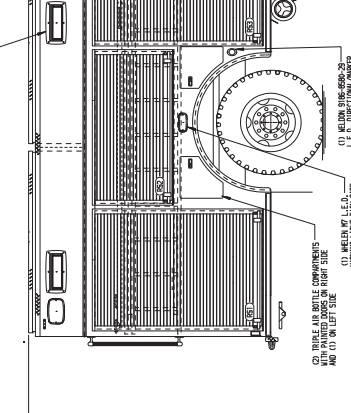
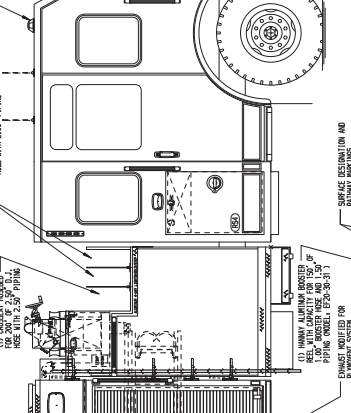
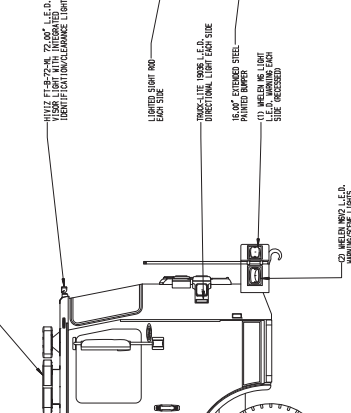
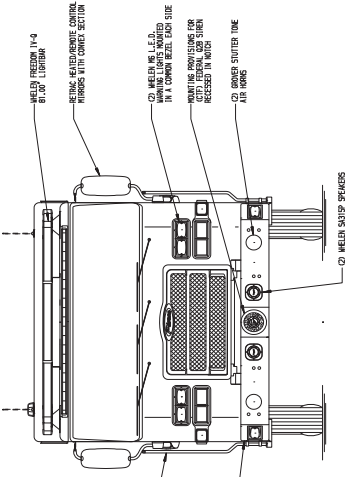

Pierce MANUFACTURING INC.

JOB NO. 36040

SCALE	DATE
1:1.24	
DRAWN BY	DATE
KLE	04MAR21
CHECKED BY	DATE
PH	04MAR21
DESIGNED BY	SHEET NO.
PH	D
DATE	1 OF 1

TITLE (3) XLAYS, GENERATOR, DELUGE, LADDERS BTWN TANK & S. SHI FOR MIDLAND PARK, NEW JERSEY

CHASSIS DATA

DESIGNER	DATE	BY	CHK	ENFORCER
KLE		PH	PH	DNG
21/ALJ		PH	PH	
11/AND		PH	PH	
05/MW		PH	PH	
11/AND		PH	PH	

NO. 1500-D-500P, 152" BODY, FDLER

ALUMINUM BODY

NOTE: DIMENSIONS SHOWN ARE APPROXIMATE AND ARE SUBJECT TO MINOR DEVIATIONS AS MAY OCCUR OR BE NECESSARY IN CONSTRUCTION. MINOR DETAILS NOT SHOWN.

- ONE ADJUSTABLE HEIGHT SLIDE-OUT PANEL LOCATED IN COMPARTMENT L5
- TABLE LIE WITHIN EACH COMPARTMENT SPEC' AND WILL NOT INTERFERE WITH EQUIPMENT
- PERMITTING WEIGHT COMPARTMENTS L5, L6, AND L7
- PERMITTING WEIGHT COMPARTMENTS L8, L9, AND L10
- PERMITTING WEIGHT COMPARTMENTS L11, L12, L13, L14, L15, L16, L17, AND L18
- PERMITTING WEIGHT COMPARTMENTS L19, L20, L21, L22, L23, L24, L25, L26, L27, AND L28
- PERMITTING WEIGHT COMPARTMENTS L29, L30, L31, L32, L33, L34, L35, L36, L37, AND L38
- PERMITTING WEIGHT COMPARTMENTS L39, L40, L41, L42, L43, L44, L45, L46, L47, AND L48
- PERMITTING WEIGHT COMPARTMENTS L49, L50, L51, L52, L53, L54, L55, L56, L57, AND L58
- PERMITTING WEIGHT COMPARTMENTS L59, L60, L61, L62, L63, L64, L65, L66, L67, AND L68
- PERMITTING WEIGHT COMPARTMENTS L69, L70, L71, L72, L73, L74, L75, L76, L77, AND L78
- PERMITTING WEIGHT COMPARTMENTS L79, L80, L81, L82, L83, L84, L85, L86, L87, AND L88
- PERMITTING WEIGHT COMPARTMENTS L89, L90, L91, L92, L93, L94, L95, L96, L97, AND L98
- PERMITTING WEIGHT COMPARTMENTS L99, L100, L101, L102, L103, L104, L105, L106, L107, AND L108
- PERMITTING WEIGHT COMPARTMENTS L109, L110, L111, L112, L113, L114, L115, L116, L117, AND L118
- PERMITTING WEIGHT COMPARTMENTS L119, L120, L121, L122, L123, L124, L125, L126, L127, AND L128
- PERMITTING WEIGHT COMPARTMENTS L129, L130, L131, L132, L133, L134, L135, L136, L137, AND L138
- PERMITTING WEIGHT COMPARTMENTS L139, L140, L141, L142, L143, L144, L145, L146, L147, AND L148
- PERMITTING WEIGHT COMPARTMENTS L149, L150, L151, L152, L153, L154, L155, L156, L157, AND L158
- PERMITTING WEIGHT COMPARTMENTS L159, L160, L161, L162, L163, L164, L165, L166, L167, AND L168
- PERMITTING WEIGHT COMPARTMENTS L169, L170, L171, L172, L173, L174, L175, L176, L177, AND L178
- PERMITTING WEIGHT COMPARTMENTS L179, L180, L181, L182, L183, L184, L185, L186, L187, AND L188
- PERMITTING WEIGHT COMPARTMENTS L189, L190, L191, L192, L193, L194, L195, L196, L197, AND L198
- PERMITTING WEIGHT COMPARTMENTS L199, L200, L201, L202, L203, L204, L205, L206, L207, AND L208
- PERMITTING WEIGHT COMPARTMENTS L209, L210, L211, L212, L213, L214, L215, L216, L217, AND L218
- PERMITTING WEIGHT COMPARTMENTS L219, L220, L221, L222, L223, L224, L225, L226, L227, AND L228
- PERMITTING WEIGHT COMPARTMENTS L229, L230, L231, L232, L233, L234, L235, L236, L237, AND L238
- PERMITTING WEIGHT COMPARTMENTS L239, L240, L241, L242, L243, L244, L245, L246, L247, AND L248
- PERMITTING WEIGHT COMPARTMENTS L249, L250, L251, L252, L253, L254, L255, L256, L257, AND L258
- PERMITTING WEIGHT COMPARTMENTS L259, L260, L261, L262, L263, L264, L265, L266, L267, AND L268
- PERMITTING WEIGHT COMPARTMENTS L269, L270, L271, L272, L273, L274, L275, L276, L277, AND L278
- PERMITTING WEIGHT COMPARTMENTS L279, L280, L281, L282, L283, L284, L285, L286, L287, AND L288
- PERMITTING WEIGHT COMPARTMENTS L289, L290, L291, L292, L293, L294, L295, L296, L297, AND L298
- PERMITTING WEIGHT COMPARTMENTS L299, L300, L301, L302, L303, L304, L305, L306, L307, AND L308
- PERMITTING WEIGHT COMPARTMENTS L309, L310, L311, L312, L313, L314, L315, L316, L317, AND L318
- PERMITTING WEIGHT COMPARTMENTS L319, L320, L321, L322, L323, L324, L325, L326, L327, AND L328
- PERMITTING WEIGHT COMPARTMENTS L329, L330, L331, L332, L333, L334, L335, L336, L337, AND L338
- PERMITTING WEIGHT COMPARTMENTS L339, L340, L341, L342, L343, L344, L345, L346, L347, AND L348
- PERMITTING WEIGHT COMPARTMENTS L349, L350, L351, L352, L353, L354, L355, L356, L357, AND L358
- PERMITTING WEIGHT COMPARTMENTS L359, L360, L361, L362, L363, L364, L365, L366, L367, AND L368
- PERMITTING WEIGHT COMPARTMENTS L369, L370, L371, L372, L373, L374, L375, L376, L377, AND L378
- PERMITTING WEIGHT COMPARTMENTS L379, L380, L381, L382, L383, L384, L385, L386, L387, AND L388
- PERMITTING WEIGHT COMPARTMENTS L389, L390, L391, L392, L393, L394, L395, L396, L397, AND L398
- PERMITTING WEIGHT COMPARTMENTS L399, L400, L401, L402, L403, L404, L405, L406, L407, AND L408
- PERMITTING WEIGHT COMPARTMENTS L409, L410, L411, L412, L413, L414, L415, L416, L417, AND L418
- PERMITTING WEIGHT COMPARTMENTS L419, L420, L421, L422, L423, L424, L425, L426, L427, AND L428
- PERMITTING WEIGHT COMPARTMENTS L429, L430, L431, L432, L433, L434, L435, L436, L437, AND L438
- PERMITTING WEIGHT COMPARTMENTS L439, L440, L441, L442, L443, L444, L445, L446, L447, AND L448
- PERMITTING WEIGHT COMPARTMENTS L449, L450, L451, L452, L453, L454, L455, L456, L457, AND L458
- PERMITTING WEIGHT COMPARTMENTS L459, L460, L461, L462, L463, L464, L465, L466, L467, AND L468
- PERMITTING WEIGHT COMPARTMENTS L469, L470, L471, L472, L473, L474, L475, L476, L477, AND L478
- PERMITTING WEIGHT COMPARTMENTS L479, L480, L481, L482, L483, L484, L485, L486, L487, AND L488
- PERMITTING WEIGHT COMPARTMENTS L489, L490, L491, L492, L493, L494, L495, L496, L497, AND L498
- PERMITTING WEIGHT COMPARTMENTS L499, L500, L501, L502, L503, L504, L505, L506, L507, AND L508
- PERMITTING WEIGHT COMPARTMENTS L509, L510, L511, L512, L513, L514, L515, L516, L517, AND L518
- PERMITTING WEIGHT COMPARTMENTS L519, L520, L521, L522, L523, L524, L525, L526, L527, AND L528
- PERMITTING WEIGHT COMPARTMENTS L529, L530, L531, L532, L533, L534, L535, L536, L537, AND L538
- PERMITTING WEIGHT COMPARTMENTS L539, L540, L541, L542, L543, L544, L545, L546, L547, AND L548
- PERMITTING WEIGHT COMPARTMENTS L549, L550, L551, L552, L553, L554, L555, L556, L557, AND L558
- PERMITTING WEIGHT COMPARTMENTS L559, L560, L561, L562, L563, L564, L565, L566, L567, AND L568
- PERMITTING WEIGHT COMPARTMENTS L569, L570, L571, L572, L573, L574, L575, L576, L577, AND L578
- PERMITTING WEIGHT COMPARTMENTS L579, L580, L581, L582, L583, L584, L585, L586, L587, AND L588
- PERMITTING WEIGHT COMPARTMENTS L589, L590, L591, L592, L593, L594, L595, L596, L597, AND L598
- PERMITTING WEIGHT COMPARTMENTS L599, L600, L601, L602, L603, L604, L605, L606, L607, AND L608
- PERMITTING WEIGHT COMPARTMENTS L609, L610, L611, L612, L613, L614, L615, L616, L617, AND L618
- PERMITTING WEIGHT COMPARTMENTS L619, L620, L621, L622, L623, L624, L625, L626, L627, AND L628
- PERMITTING WEIGHT COMPARTMENTS L629, L630, L631, L632, L633, L634, L635, L636, L637, AND L638
- PERMITTING WEIGHT COMPARTMENTS L639, L640, L641, L642, L643, L644, L645, L646, L647, AND L648
- PERMITTING WEIGHT COMPARTMENTS L649, L650, L651, L652, L653, L654, L655, L656, L657, AND L658
- PERMITTING WEIGHT COMPARTMENTS L659, L660, L661, L662, L663, L664, L665, L666, L667, AND L668
- PERMITTING WEIGHT COMPARTMENTS L669, L670, L671, L672, L673, L674, L675, L676, L677, AND L678
- PERMITTING WEIGHT COMPARTMENTS L679, L680, L681, L682, L683, L684, L685, L686, L687, AND L688
- PERMITTING WEIGHT COMPARTMENTS L689, L690, L691, L692, L693, L694, L695, L696, L697, AND L698
- PERMITTING WEIGHT COMPARTMENTS L699, L700, L701, L702, L703, L704, L705, L706, L707, AND L708
- PERMITTING WEIGHT COMPARTMENTS L709, L710, L711, L712, L713, L714, L715, L716, L717, AND L718
- PERMITTING WEIGHT COMPARTMENTS L719, L720, L721, L722, L723, L724, L725, L726, L727, AND L728
- PERMITTING WEIGHT COMPARTMENTS L729, L730, L731, L732, L733, L734, L735, L736, L737, AND L738
- PERMITTING WEIGHT COMPARTMENTS L739, L740, L741, L742, L743, L744, L745, L746, L747, AND L748
- PERMITTING WEIGHT COMPARTMENTS L749, L750, L751, L752, L753, L754, L755, L756, L757, AND L758
- PERMITTING WEIGHT COMPARTMENTS L759, L760, L761, L762, L763, L764, L765, L766, L767, AND L768
- PERMITTING WEIGHT COMPARTMENTS L769, L770, L771, L772, L773, L774, L775, L776, L777, AND L778
- PERMITTING WEIGHT COMPARTMENTS L779, L780, L781, L782, L783, L784, L785, L786, L787, AND L788
- PERMITTING WEIGHT COMPARTMENTS L789, L790, L791, L792, L793, L794, L795, L796, L797, AND L798
- PERMITTING WEIGHT COMPARTMENTS L799, L800, L801, L802, L803, L804, L805, L806, L807, AND L808
- PERMITTING WEIGHT COMPARTMENTS L809, L810, L811, L812, L813, L814, L815, L816, L817, AND L818
- PERMITTING WEIGHT COMPARTMENTS L819, L820, L821, L822, L823, L824, L825, L826, L827, AND L828
- PERMITTING WEIGHT COMPARTMENTS L829, L830, L831, L832, L833, L834, L835, L836, L837, AND L838
- PERMITTING WEIGHT COMPARTMENTS L839, L840, L841, L842, L843, L844, L845, L846, L847, AND L848
- PERMITTING WEIGHT COMPARTMENTS L849, L850, L851, L852, L853, L854, L855, L856, L857, AND L858
- PERMITTING WEIGHT COMPARTMENTS L859, L860, L861, L862, L863, L864, L865, L866, L867, AND L868
- PERMITTING WEIGHT COMPARTMENTS L869, L870, L871, L872, L873, L874, L875, L876, L877, AND L878
- PERMITTING WEIGHT COMPARTMENTS L879, L880, L881, L882, L883, L884, L885, L886, L887, AND L888
- PERMITTING WEIGHT COMPARTMENTS L889, L890, L891, L892, L893, L894, L895, L896, L897, AND L898
- PERMITTING WEIGHT COMPARTMENTS L899, L900, L901, L902, L903, L904, L905, L906, L907, AND L908
- PERMITTING WEIGHT COMPARTMENTS L909, L910, L911, L912, L913, L914, L915, L916, L917, AND L918
- PERMITTING WEIGHT COMPARTMENTS L919, L920, L921, L922, L923, L924, L925, L926, L927, AND L928
- PERMITTING WEIGHT COMPARTMENTS L929, L930, L931, L932, L933, L934, L935, L936, L937, AND L938
- PERMITTING WEIGHT COMPARTMENTS L939, L940, L941, L942, L943, L944, L945, L946, L947, AND L948
- PERMITTING WEIGHT COMPARTMENTS L949, L950, L951, L952, L953, L954, L955, L956, L957, AND L958
- PERMITTING WEIGHT COMPARTMENTS L959, L960, L961, L962, L963, L964, L965, L966, L967, AND L968
- PERMITTING WEIGHT COMPARTMENTS L969, L970, L971, L972, L973, L974, L975, L976, L977, AND L978
- PERMITTING WEIGHT COMPARTMENTS L979, L980, L981, L982, L983, L984, L985, L986, L987, AND L988
- PERMITTING WEIGHT COMPARTMENTS L989, L990, L991, L992, L993, L994, L995, L996, L997, AND L998
- PERMITTING WEIGHT COMPARTMENTS L999, L1000, L1001, L1002, L1003, L1004, L1005, L1006, L1007, AND L1008