



Pierce Enforcer PUC Pumper
Mendham Township/Ralston Engine Co. #1
Job #33825

FEATURES & SPECIFICATIONS

- Pierce Enforcer 70" Chassis with a 10" Raised Roof
- Cummins L9 450HP 2017 EPA compliant Engine
- Allison EVS3000P Automatic Transmission
- Dana Front and Rear Axles
- Pierce PUC 1500 GPM Single Stage Pump
- 1000 Gallon Poly Water Tank
- Husky 3 Single Agent Foam System
- Hercules 140CFM CAFS System
- Delivered in February 2020



FIRE & SAFETY SERVICES, LTD.
South Plainfield, NJ
web: www.f-ss.com · phone: 800-400-8017

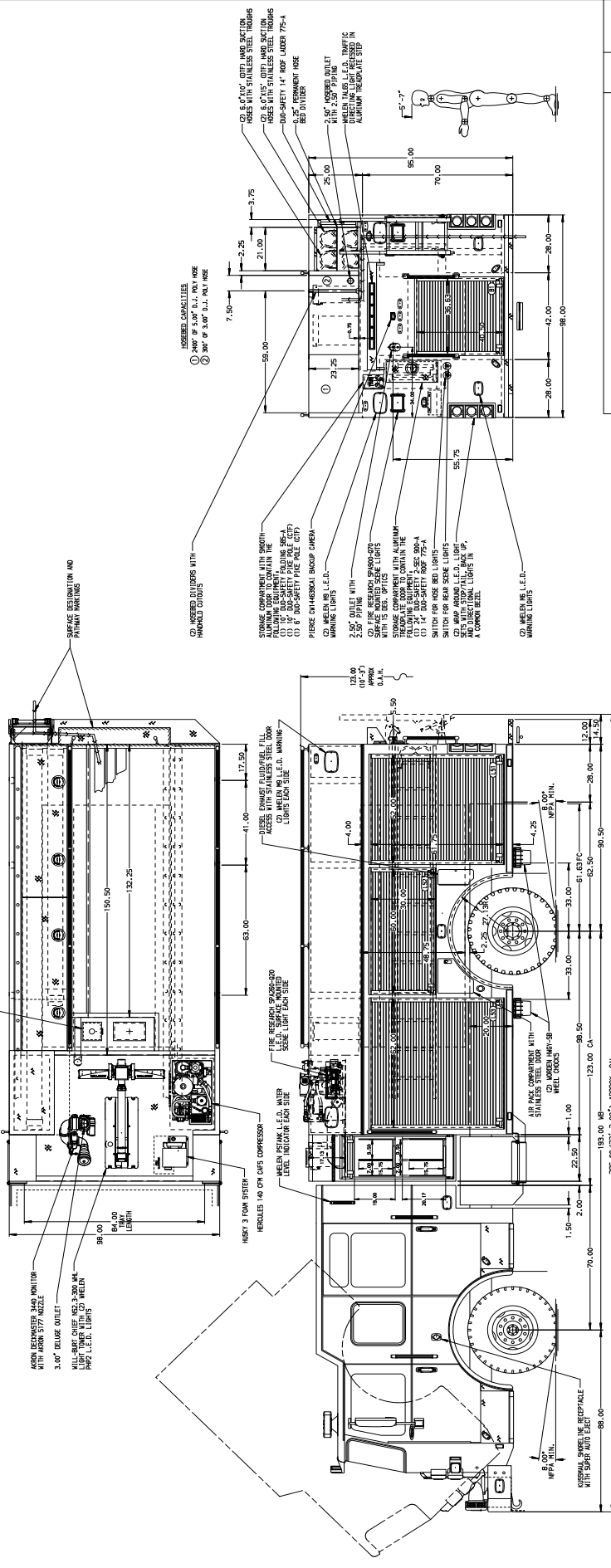
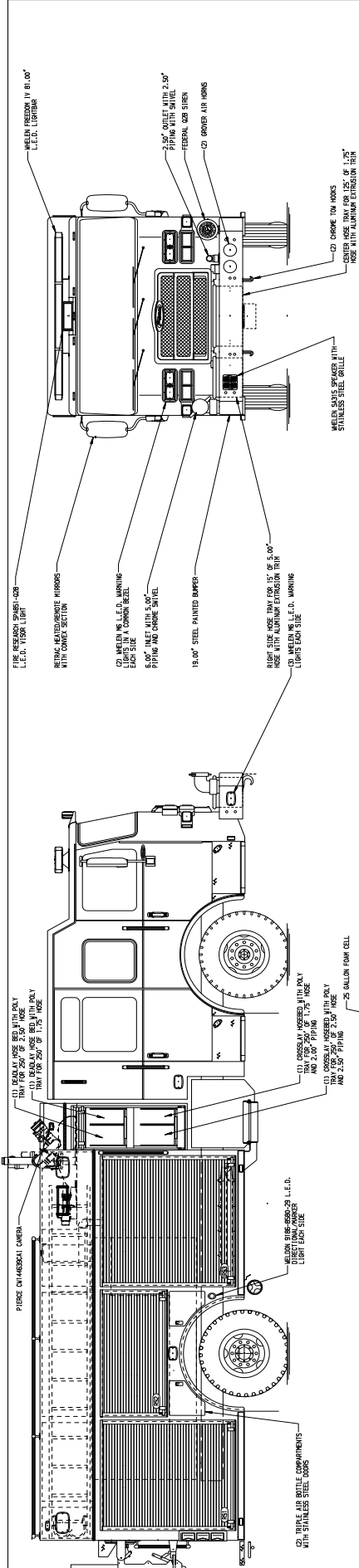

Pierce MANUFACTURING INC.

JOB NO. 33825

SCALE 1:24 DATE

DESIGN BY 03MAY19

CHECKED BY KOJ 06MAY19

REV. DATE BY CH ENFORCER NO.

33825AD

CHASSIS DATA
 TITLE 1500-D-1000P-W/25 GAL. FOAM CELL, HUSKY 3-LIGHT TONER
 MAKE PIERCE
 MODEL DNG

REV. DATE BY CH ENFORCER NO.

1 1 OF 1

ALUMINUM BODY SIDE ROLL AND FRONTAL IMPACT PROTECTION

NOTE: DIMENSIONS SHOWN ARE APPROXIMATE AND ARE SUBJECT TO MINOR DEVIATIONS AS MAY OCCUR OR BE NECESSARY IN CONSTRUCTION. MINOR DETAILS NOT SHOWN.

1. WELDING SHALL BE WELDED IN COMPARTMENT-45 (SEE SHEET 040-45)

2. WELDED JOINTS SHALL BE WELDED IN COMPARTMENT-45 (SEE SHEET 040-45)

3. ALL DIMENSIONS ARE APPROXIMATE DIMENSIONS UNLESS SPECIFICALLY NOTED OTHERWISE

4. ALL DIMENSIONS ARE APPROXIMATE DIMENSIONS UNLESS SPECIFICALLY NOTED OTHERWISE

5. ALL DIMENSIONS ARE APPROXIMATE DIMENSIONS UNLESS SPECIFICALLY NOTED OTHERWISE

6. WELDED JOINTS SHALL BE WELDED IN COMPARTMENT-45 (SEE SHEET 040-45)

7. WELDED JOINTS SHALL BE WELDED IN COMPARTMENT-45 (SEE SHEET 040-45)

8. WELDED JOINTS SHALL BE WELDED IN COMPARTMENT-45 (SEE SHEET 040-45)

9. WELDED JOINTS SHALL BE WELDED IN COMPARTMENT-45 (SEE SHEET 040-45)

10. WELDED JOINTS SHALL BE WELDED IN COMPARTMENT-45 (SEE SHEET 040-45)

11. WELDED JOINTS SHALL BE WELDED IN COMPARTMENT-45 (SEE SHEET 040-45)

12. WELDED JOINTS SHALL BE WELDED IN COMPARTMENT-45 (SEE SHEET 040-45)

13. WELDED JOINTS SHALL BE WELDED IN COMPARTMENT-45 (SEE SHEET 040-45)

14. WELDED JOINTS SHALL BE WELDED IN COMPARTMENT-45 (SEE SHEET 040-45)

15. WELDED JOINTS SHALL BE WELDED IN COMPARTMENT-45 (SEE SHEET 040-45)